

GIGAbend

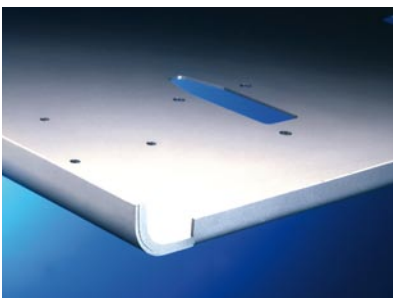

GIGAbend

GIGAbend – Gigantically Powerful!

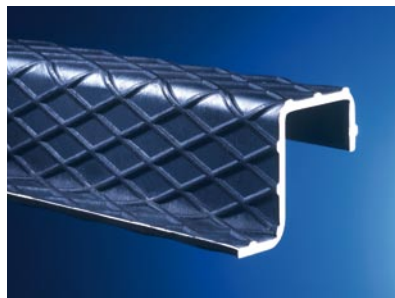
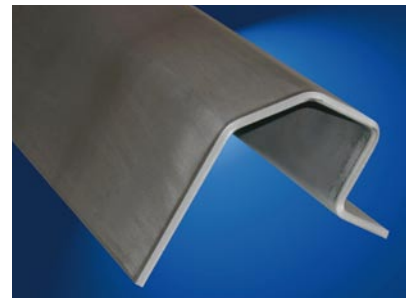
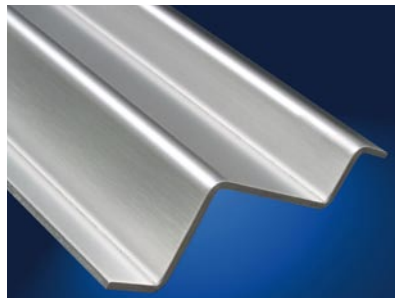

Never before in metal folding has power and speed been brought together so precisely. Power to bend thick materials and to close hems. Speed for higher throughput and perfect quality parts.

If your business is folding metal chassis, covers, enclosures, boxes or cabinets, and you do not want to limit your design ideas by the capabilities of a machine, the GIGAbend is the ideal metal folding system for you.

What makes the GIGAbend so unique?

With an innovative 3-axes servo-hybrid drive system for the upper beam, the RAS engineering team again has set new standards in the metal folding market. The upper beam clamps the workpieces powerfully, quickly and dynamically. 120 metric tons (130 US tons) of clamping pressure – unheard of in a folding machine – insure that the GIGAbend delivers more than adequate power for closing hems.

Pure perfection is achieved with the intelligent folding beam crowning system. Integrated sensors measure the real beam deflection during bending and the intelligent crowning system automatically compensates for any unevenness. You focus on your parts and the machine does the rest!

**RAS Folding:
Gigantically brilliant!**

GIGAbend



The Integrated Backgauge and Sheet Support System

The GIGAbend is complete with a CNC backgauge including a high quality sheet support system and integrated ball casters. The heavy material weight of large blanks is fully supported by this system to insure the operator can handle even large blanks effortlessly. The solid and laterally movable stop finger units come with multiple hardened stop fingers. These fingers

automatically position the part to the bend line. They can reach any position in less than 2 seconds. Apart from the rectangular backgauge, RAS offers a “J” or “U” shape backgauge for large blanks. The CNC is integrated

into a swivel arm, so that the machine can be operated from the front or rear without losing any valuable program information.

Gigantically versatile!

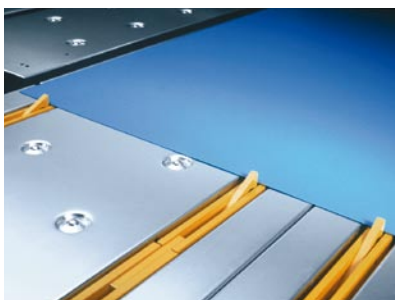
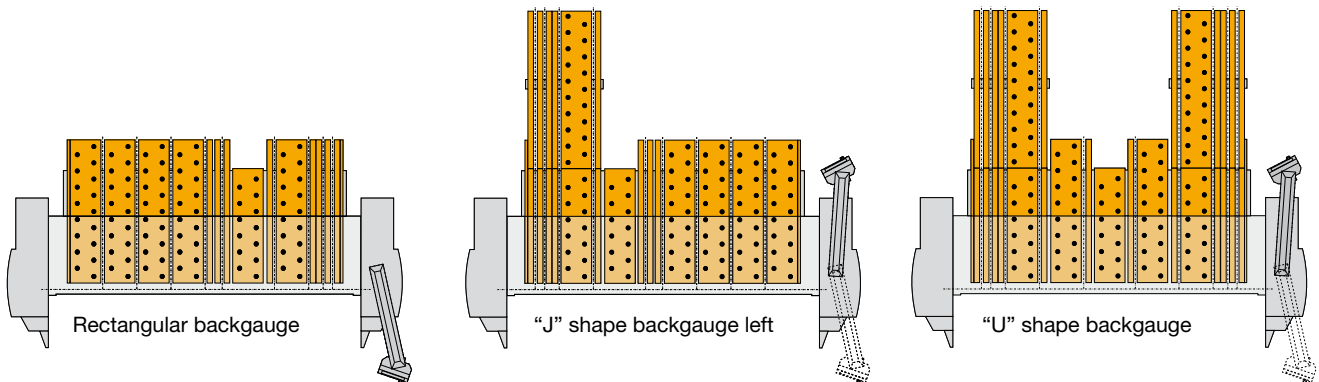

The front or rear pop-up fingers position the part to the programmed dimension.



The front fingers can move into the lower beam tool finger pockets.

GIGAbend

GIGAbend – Gigantically Perfect!



The upper beam tool clamping system automatically locks the tools into place.

The Upper Clamping Beam

The innovative 3-axes servo-hybrid drive system opens and closes the upper beam to the programmed dimension. Patented PowerBoosters create up to 120 metric tons (130 US tons) of clamping pressure. This power is used to close



PowerBoosters create 120 metric tons (130 US tons) of pressure. Result: Perfect hems and tight bend radii.

hems on thicker materials and to safely hold the material for tight bend radii. With an upper beam open height of 500 mm (19.6”), the machine has a tremendous

amount of flexibility to do deep boxes. An integrated tool clamping system automatically locks the upper beam tools in position. This is ideal when you run small batch sizes and change setups frequently.

Gigantically innovative!

The Pivot Point Adjustment

As another innovation, RAS presents a pivot point adjustment for the folding beam. This new automatic system guarantees perfect parts, no matter if you prefer a sharp or more generous bend radius.

Gigantically different!

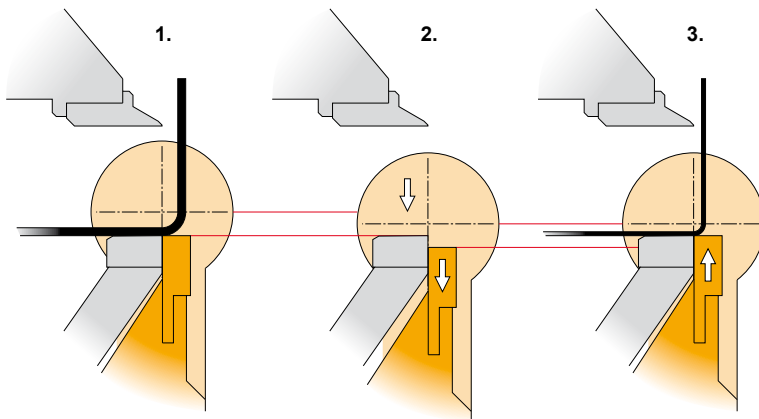

The automatic pivot point and folding beam adjustment sets the machine for material thickness and achieves perfect bend radii



The automatic pivot point adjustment guarantees perfect parts.

GIGAbend

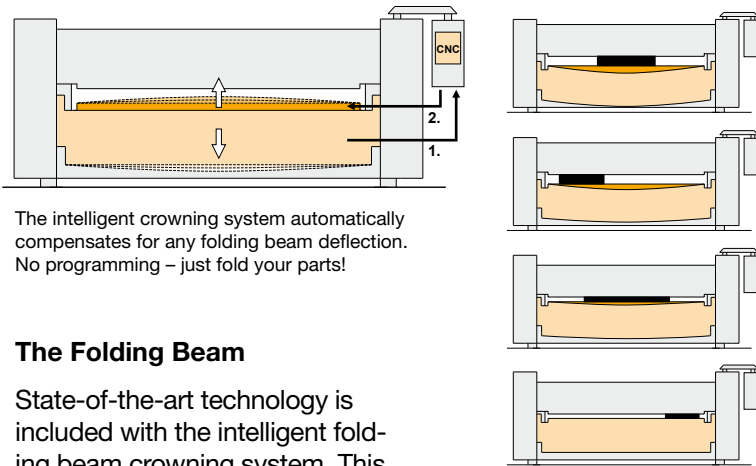

The intelligent crowning system automatically compensates for any folding beam deflection. No programming – just fold your parts!

The Folding Beam

State-of-the-art technology is included with the intelligent folding beam crowning system. This system always creates straight parts whether you bend thick or thin material, work with mild steel or stainless, fold short or long flanges, run the part in the center of the machine or on one side. And the best: the crowning system does it all by itself. No programming – just fold your parts!

The tool clamping system locks the folding beam tools into position as soon as you start the folding cycle.

Gigantically imaginative!

The RAS Tooling System

High tensile strength, plasma hardened and precision ground tools offer maximum free space for even the most difficult parts. Tool segments not exceeding 200 mm (7.87") make any tool change simple and easy. Tool clamping systems integrated in the upper and folding beam automatically lock the tools into position! If the "standard" free spaces are not adequate for a certain part, RAS offers the XL tools for the upper and folding beam.

Gigantically flexible!

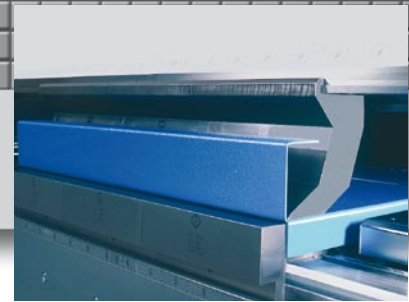

Segmented lower beam tools for reverse flanges of up to 40 mm (1.575").

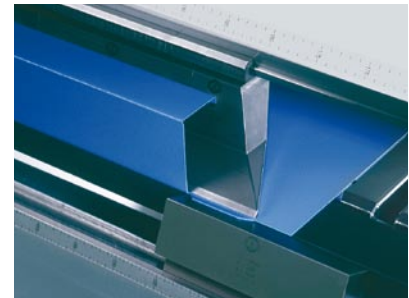

Segmented tools with generous free space add flexibility in any situation (Sample: welding tabs).

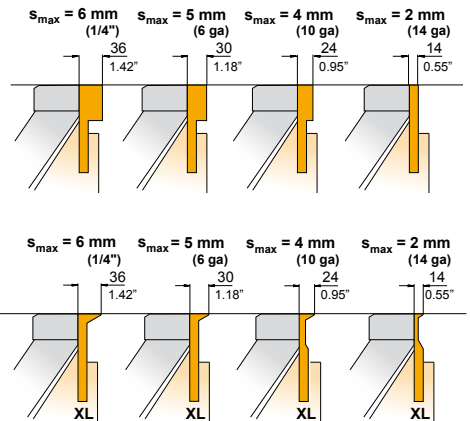

Also for the folding beam there are "standard" and XL tools available.

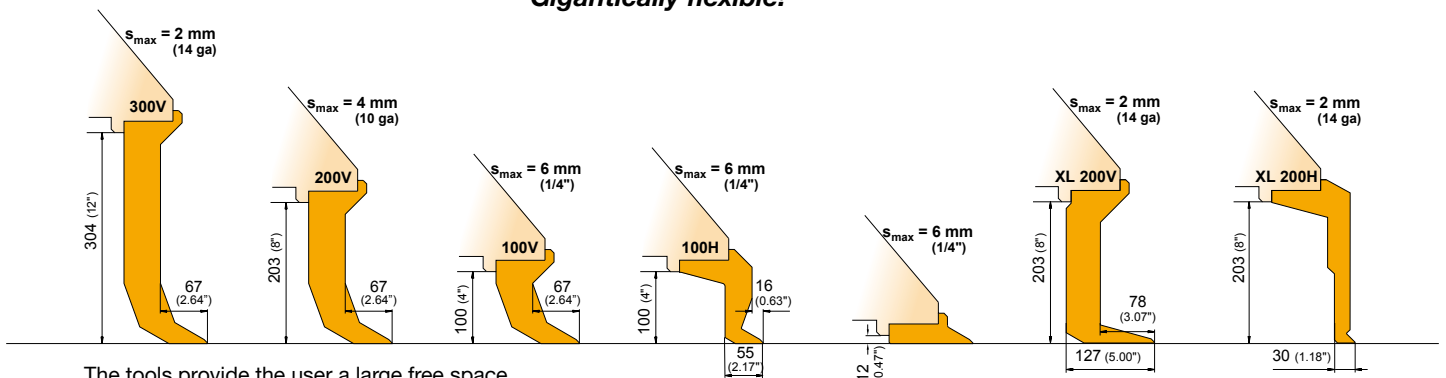

The tools provide the user a large free space for very creative part designs.

GIGAbend

Automatic programming: Gigantically simple!

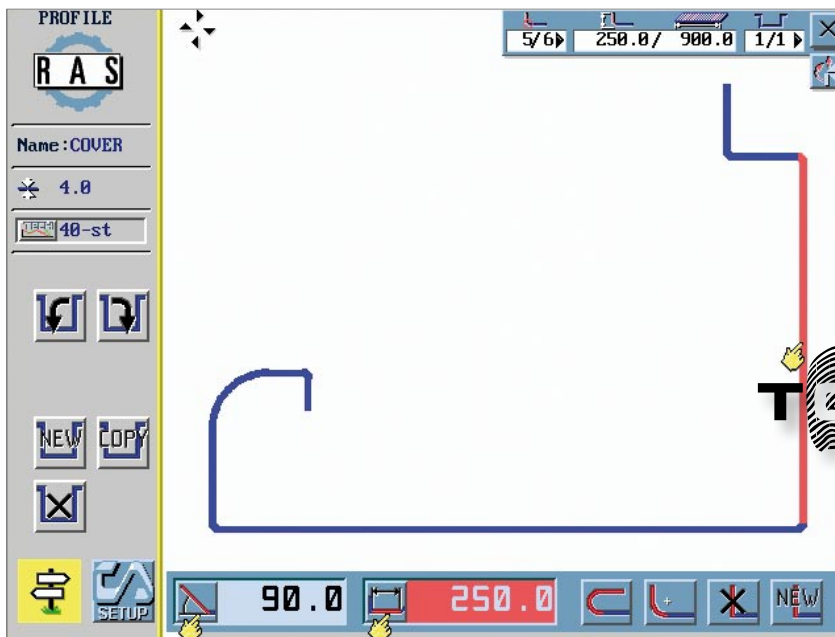

Pictures become Parts!

If you program on the shop floor, your finger can be used as a pencil. Simply paint a flange and size it to the right dimension and angle.

TOUCH & More

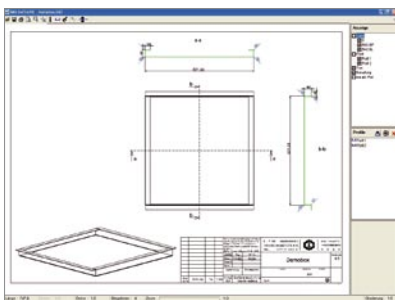

If you program in the office, you can use the offline software on your PC. There, you can also draw the shape of your parts, or you can import a part graphic using the RAS dxf converter.

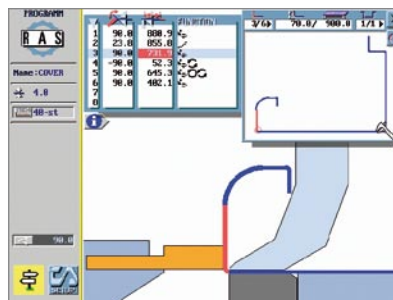

The CADalyzer calculates several folding sequences and for most parts automatically creates a program. The simulation shows the program, the finished part and the actual bend sequence.

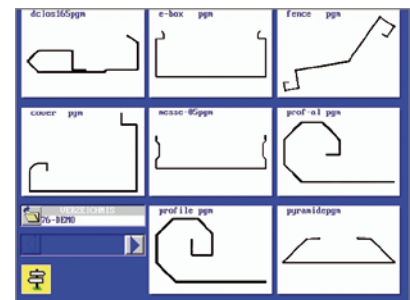

Locate a part program stored in the RAM or on USB memory visually in the easy to use program library. To create a part icon the Touch&More offers a photo function.

GIGAbend

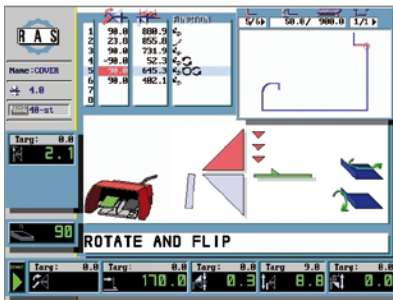

After the program is started, the graphic shows the operator which foot pedal he needs to press. Operator instructions such as "Flip" or "Paint up" allow even inexperienced operators to produce perfect parts.

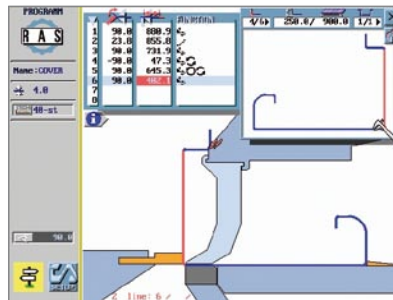

If a collision has been analyzed, the control displays this situation graphically. Technology tables consider material springback. The calculated blank dimensions are automatically corrected by the bend allowance, used for the radii.

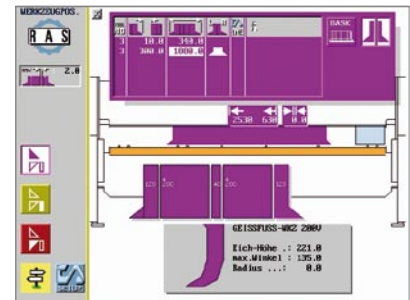

The setup instruction displays which tool segments are required for the length of the part. This information is available for the upper beam, the folding beam and the lower beam. For easy setup, the Touch&More graphically displays the tool shape.

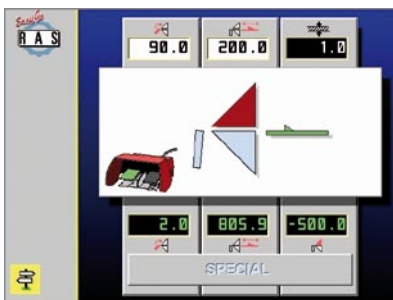

If someone operates the machine occasionally, he can use the EasyGo operation. Simply enter an angle, a backstop dimension and the material thickness and you are ready to go. If you want to bend "by eye" just press the push buttons in the Special menu and start each machine movement separately.





GIGAbend

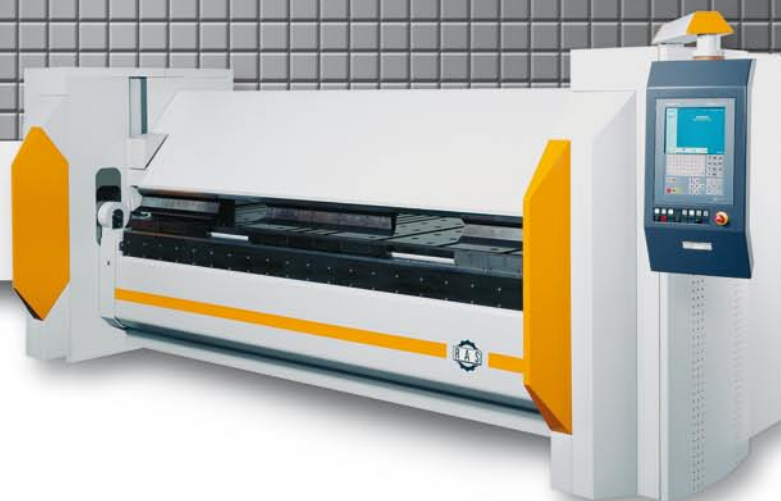

Folding system

Technical Data	RAS 76.40		RAS 76.30	
Sheet Thickness max. (Mild Steel)	5 mm	6 ga.	6 mm	1/4"
Sheet Thickness max. (Stainless)	3 mm	11 ga.	4 mm	9 ga.
Working Length	4060 mm	159.8"	3200 mm	125.9"
Backgauge Depth (Rectangular)	10 – 1550 mm	0.4" – 61"	10 – 1550 mm	0.4" – 61"
Backgauge Depth ("J" shape)	10 – 3050 (4100) mm	0.4" – 120" (161")	10 – 3050 (4100) mm	0.4" – 120" (161")
Backgauge Depth ("U" shape)	10 – 3050 (4100) mm	0.4" – 120" (161")	10 – 3050 (4100) mm	0.4" – 120" (161")
Backgauge Accuracy	+/- 0.1 mm	+/- 0.004"	+/- 0.1 mm	+/- 0.004"
Upper Beam Open Height max.	500 mm	19.7"	500 mm	19.7"
Upper Beam Clamping Pressure	120 metric tons	130 US tons	120 metric tons	130 US tons
CNC Folding Beam Adjustment max.	80 mm	3.15"	80 mm	3.15"
CNC Lower Beam Adjustment max.	80 mm	3.15"	80 mm	3.15"
Working Height	950 mm	37.4"	950 mm	37.4"
Machine Length	5500 mm	217"	4700 mm	185"
Machine Width	2450 mm	97"	2450 mm	97"
Machine Height	2050 mm	81"	2050 mm	81"
Machine Weight about	11000 kg	24,300 lbs	8600 kg	19,000 lbs
Air Pressure	5.5 bar	73 PSI	5.5 bar	73 PSI
Drive Power Upper Beam	15 kW	20.6 hp	15 kW	20.6 hp
Speeds				
Folding Beam Speed	80 deg/s	80 deg /s	80 deg /s	80 deg /s
Upper Beam Speed	60 mm/s	2.36"/s	60 mm/s	2.36"/s
Backgauge Speed 10 – 1550 mm (0.4" – 61")	1.9 s	1.9 s	1.9 s	1.9 s

RAS Reinhardt Maschinenbau GmbH
 Richard-Wagner-Str. 4–10
 71065 Sindelfingen · Germany
 Tel. +49-7031-863-0
 Fax +49-7031-863-185

www.RAS-online.de
Info@RAS-online.de

Modifications reserved. Pictures may show options.