

TURBObend plus

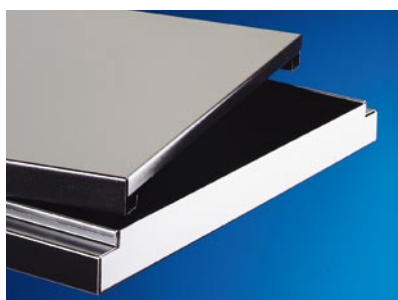

TURBObend plus

Versatile and fast

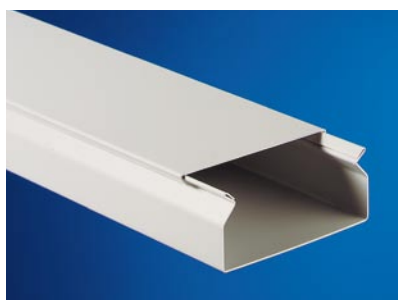
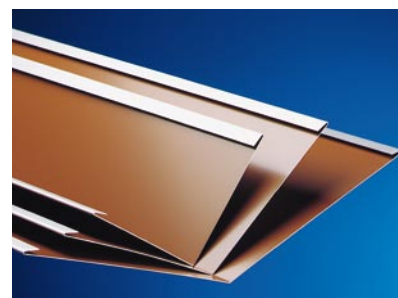
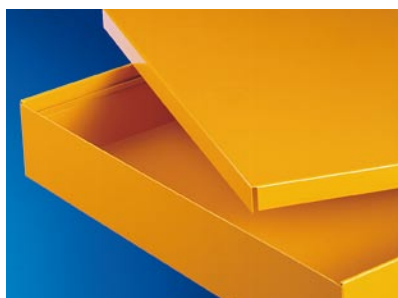

Now you can have it all: speed, flexibility, power and the added versatility for profiles and four sided boxes. If you are in the architectural, roofing, metal construction, sign business, or simply need maximum flexibility in your job shop business, the TURBObend plus is the machine for you!

You will be fascinated by the easy to use Touch&More control. With the revolutionary RAS programming system the operator simply uses his finger as a pencil. He draws a flange and sizes it with his finger to the right dimension and angle. The Touch&More screen shows the finished part, simulates the folding sequence and shows whether the part can be folded or not. The CADalyzer automatically creates the program for most parts and shows the program, the finished part and the actual bend sequence all at one time.



TURBObend plus

The Backgauge System

A positive plus is the increased versatility of the backgauge system. Each stop finger unit comes with three pop-up fingers. A servo motor positions the backgauge to any dimension in under 2 seconds.

The operator can run small parts from the front of the machine. For larger parts the backgauge system can be configured as "J" or "U" shape. The operator manipulates heavier workpieces from the rear of the machine. With the simplified handling one operator can handle even very large workpieces with ease.

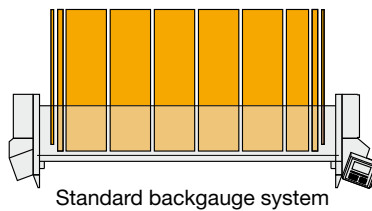
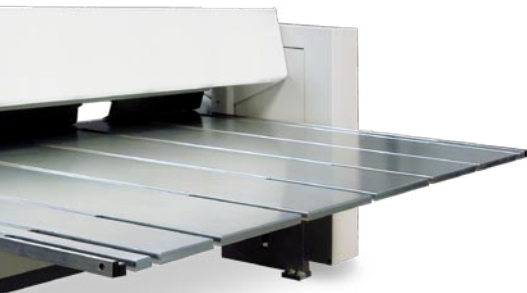

Front stop fingers

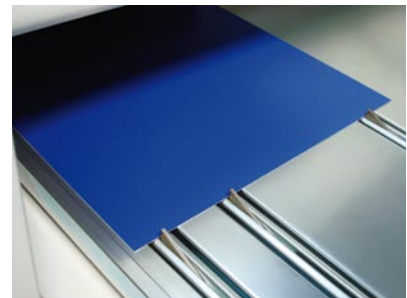
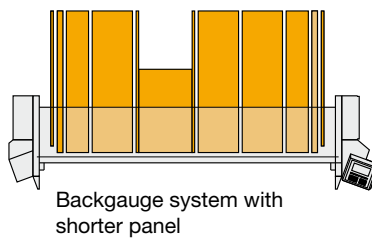

Middle stop fingers

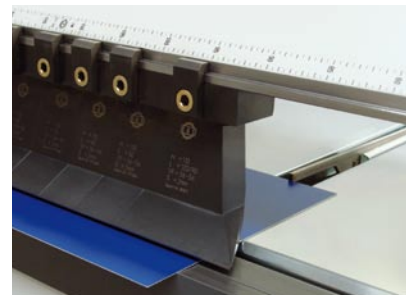
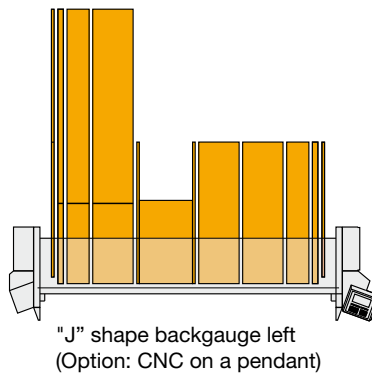

Stop situation

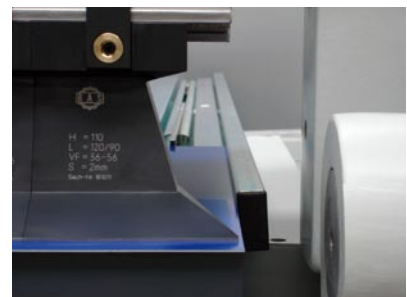
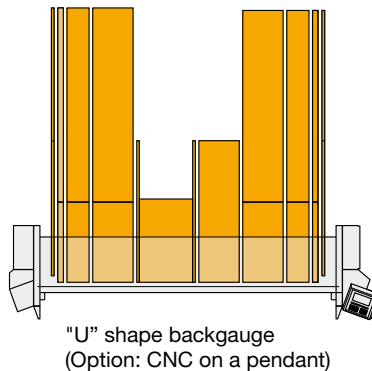

Squaring arm for long but narrow parts

TURBObend plus

Put your shop in the Plus column!

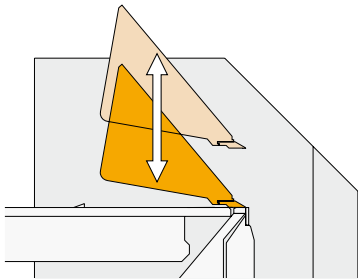

Programmable upper clamping beam for open and closed hems

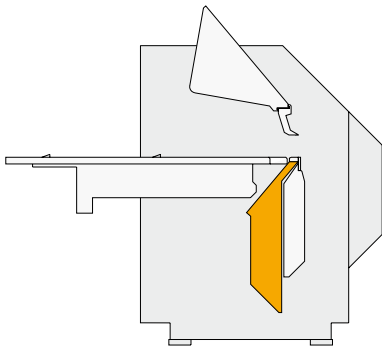

The extra deep lower clamping beam offers maximum resistance to deflection and torsion free rigidity

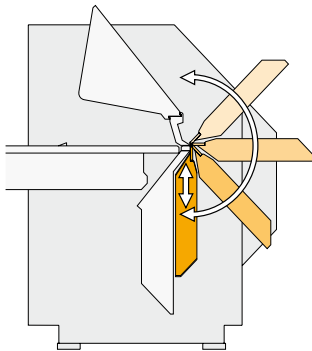

The folding beam reaches its position with a 0.1 degree accuracy

The Upper Clamping Beam

beam and can open it to a height of 200 mm (7.87"). With infinite programmability of the open and closed stroke position, you can create many varieties of hems, thus making your parts unique and very versatile. The special upper clamping beam shape offers an extra large area in front of the beam. A Plus allowing you to create your parts with flexibility never before available!

The Lower Beam

The lower clamping beam is designed with a deep box type configuration. It is directly linked to the side frame creating maximum resistance to deflection and torsion free rigidity. A Plus that will come to value every day to create extremely accurate parts!

The Folding Beam

Designed for minimum deflection, the folding beam on the TURBObend plus guarantees accurate and precise parts. With accuracy and lightning fast speed, your productivity is insured. The folding beam automatically adjusts for different material thicknesses.

This ensures that folding forces are directed into the beam and the lifetime of your investment is increased.

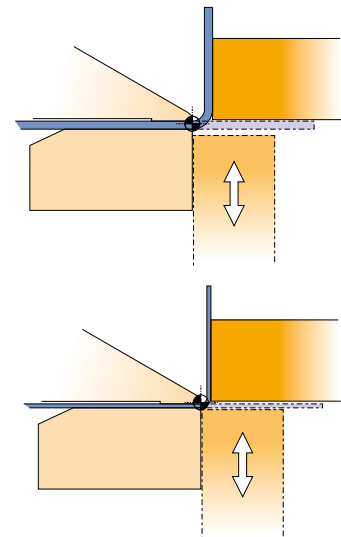

Automatic folding beam adjustment for different material thicknesses in less than 10 seconds

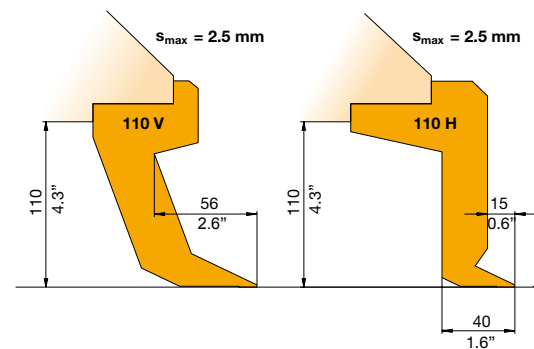

TURBObend plus



With the quick clamp system, tools can be changed in seconds

The RAS Tooling System

The three segments of sharp tooling are mounted to the upper clamping beam and can be removed in seconds by the operator. The goat's foot tooling is precision ground. It is quick-clamped and locks in position so that it is ready to work within seconds. Tool segments not exceeding 200 mm (7.874") length make it extremely simple to rearrange tools. Four sided boxes can be as high as 110 mm (4.3"). No other tool system offers so much free space for all kinds of folding geometries. If the "standard" free spaces are still not enough, ask for the XL tools! They offer even more free space in front or behind the tools. A Plus for maximum design flexibility!

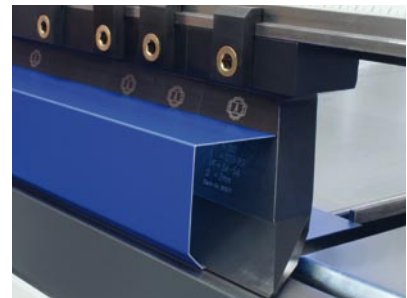

The front free tools with extremely large free space for long in-flanges

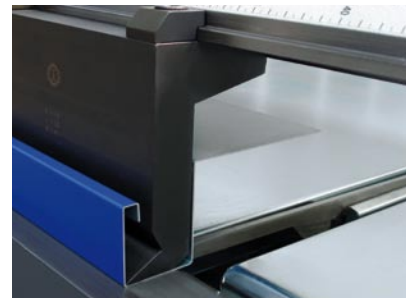

Rear free tools for slim and narrow parts

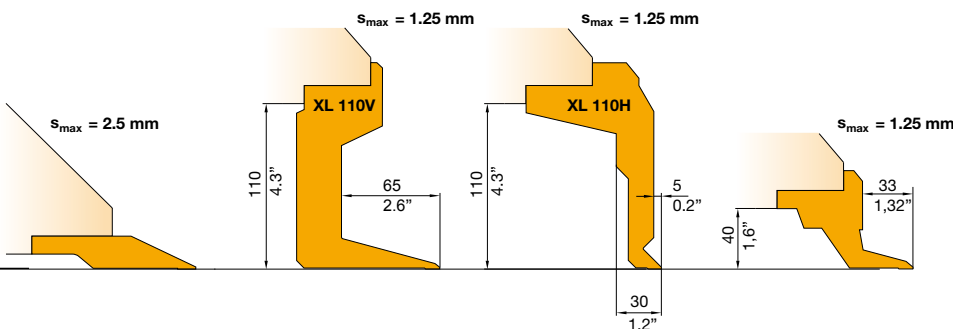

The sharp tool

TURBObend plus

Automatic programming

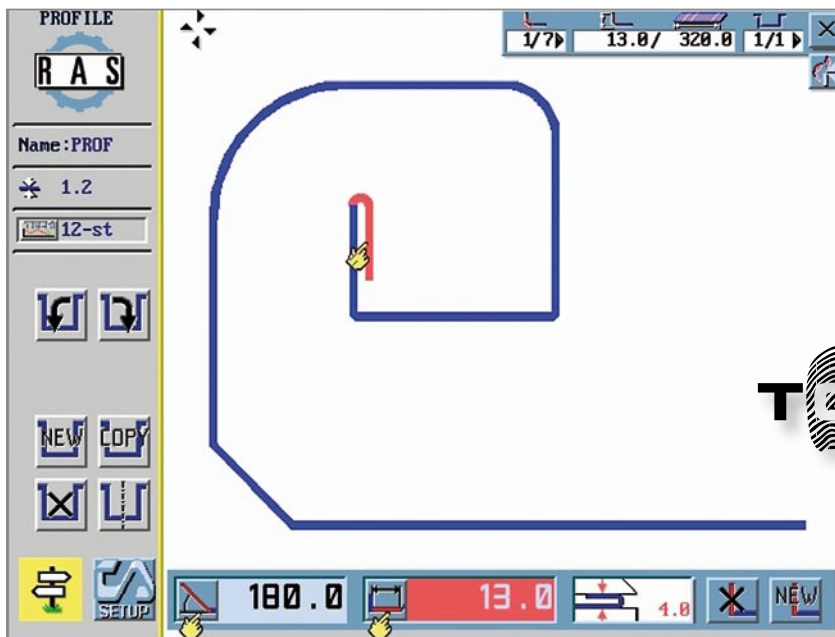

Pictures become Parts!

If you program on the shop floor, your finger is all you need. Simply paint a flange and size it to the right dimension and angle.

TOUCH & More

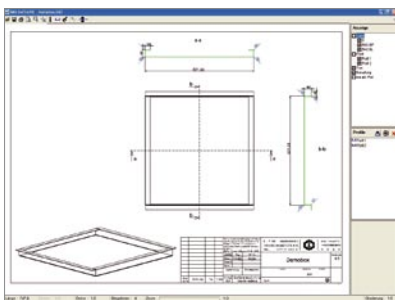

If you program in the office, you can use the offline software on your PC. There, you can also draw the shape of your parts, or you can import a part graphic using the RAS dxf converter.

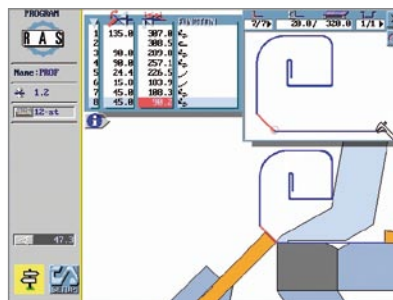

The CADalyzer calculates several folding sequences and for most parts automatically creates a program. The simulation shows the program, the finished part and the actual bend sequence.

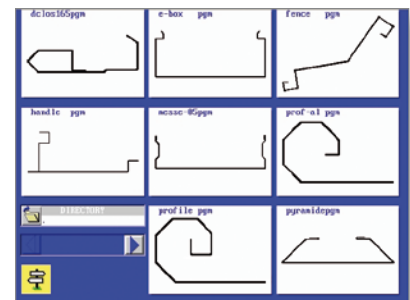

Locate a part program stored in the RAM or on USB memory visually in the easy to use program library. To create a part icon the Touch&More offers a photo function.

TURBObend plus

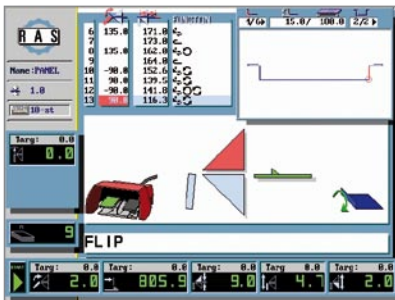

After the program is started, the graphic shows the operator which foot pedal he needs to press. Operator instructions such as “Flip” or “Paint up” allow even inexperienced operators to produce perfect parts.



Ergonomically positioned Touch&More control for optimum visibility
(Optional: Control on swivel arm)

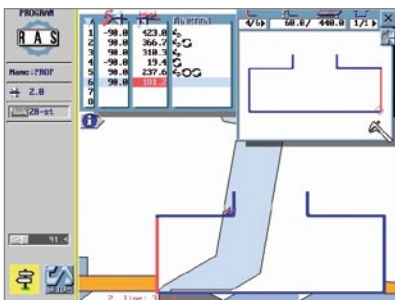

If a collision has been analyzed, the control displays this situation graphically. Standard RAS technology tables consider material springback. The calculated blank dimensions are automatically corrected by the bend allowance used for the radii.

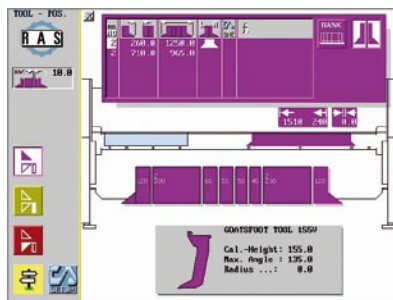

The setup instruction displays which tool segments are required for the length of the part. This information is available for the upper beam and the folding beam. For easy setup, the Touch&More graphically displays the tool shape.



If someone operates the machine occasionally, he can use the EasyGo operation. Simply enter an angle, a backstop dimension and the material thickness and you are ready to go. If you want to bend “by eye” just press the push buttons in the Special menu and start each machine movement separately.



TURBObend plus



Folding system

Technical Data	RAS 62.30		RAS 62.25	
Sheet Thickness max. (Mild Steel)	2 mm	14 ga.	2.5 mm	13 ga.
Working Length	3200 mm	125.9"	2540 mm	100"
Backgauge Depth (Standard)	6 – 1550 mm	0.24" – 61"	6 – 1550 mm	0.24" – 61"
Backgauge Accuracy	+/- 0.15 mm	+/- 0.006"	+/- 0.15 mm	+/- 0.006"
Upper Beam Open Height max	200 mm	7.87"	200 mm	7.87"
CNC Folding Beam Adjustment max.	5.5 mm	0.2"	5.5 mm	0.2"
Working Height	850 mm	33.5"	850 mm	33.5"
Machine Length	4340 mm	170.0"	3690 mm	145"
Machine Width	2100 mm	83.7"	2100 mm	83.7"
Machine Height	1380 mm	54.5"	1380 mm	54.5"
Machine Weight about	3500 kg	7725 lbs	2800 kg	6180 lbs
Air Pressure	5 bar	72.5 PSI	5 bar	72.5 PSI
Drive Power Upper Beam	1.1 kW	1.5 hp	1.1 kW	1.5 hp
Drive Power Folding Beam	2.2 kW	3.0 hp	2.2 kW	3.0 hp
Speeds				
Upper Beam Speed	26 mm/s	1.0"/sec	26 mm/s	1.0"/sec
Folding Beam Speed	80 Grad/s	80 deg/sec	80 Grad/s	80 deg/sec
Backgauge Speed 10 – 1550 mm (0.4" – 61")	1.9 s	1.9 sec	1.9 s	1.9 sec

RAS Reinhardt Maschinenbau GmbH
 Richard-Wagner-Str. 4–10
 71065 Sindelfingen · Germany
 Tel. +49-7031-863-0
 Fax +49-7031-863-185

www.RAS-online.de
Info@RAS-online.de

Modifications reserved. Pictures may show options.