

UpDownBend

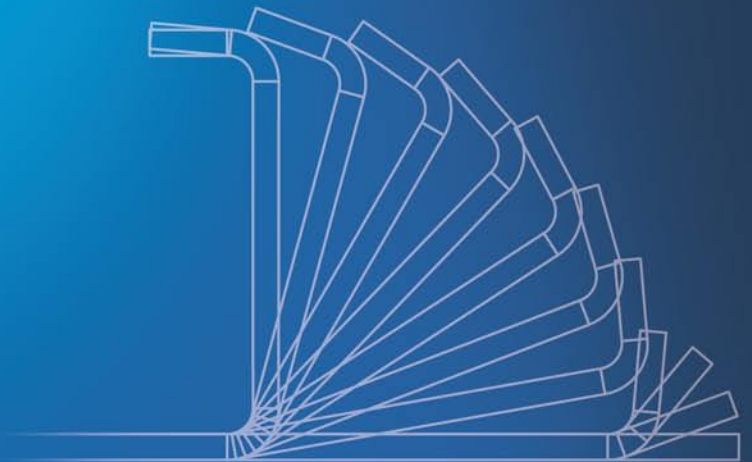

- Cutting
- Bending
- Forming



UpDownBend

No more flipping parts!



Folding a profile



Closing a profile

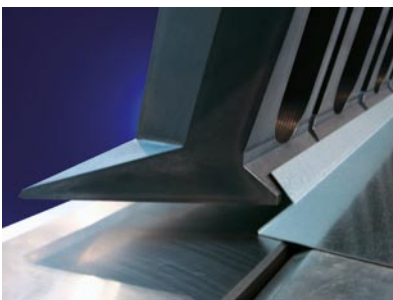

Closing a hem

No flipping

The UpDownBend folds the part up and down and revolutionizes the entire folding sequence. This unique folding system reduces cycle times and eliminates the need for a second operator. State-of-the-art servo-drive technology permits dynamic movements of the upper beam, folding beam and the gauging system. It underlines the strong-vital character of the UpDownBend.

***The UpDownBend:
Dynamic features and benefits!
Huge economic value!***

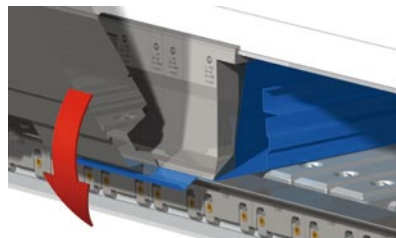
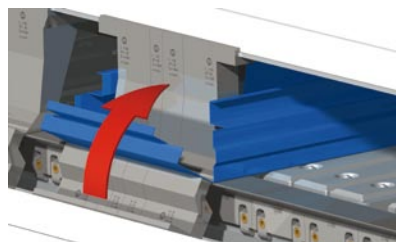

Folding up and down



Telescopic gauging system

Constantly supported

The telescopic gauging system automatically adjusts its size to the current folding position. When parts are small or narrow, the table surface area decreases. On large sheets this surface unfolds to its maximum dimension. Since the workpiece is constantly supported, the operator does not need to hold or raise it – and the cycle time is accelerated.

***The UpDownBend:
Your pole position for the future!***

UpDownBend

Easy to access

With the telescoping gauging system paired with an upper beam shape that steeply angles upward, the operator has perfect access to the bend line and can handle small parts easily. At the same time, the gauging system keeps the operator a safe distance outside the folding area.

*The UpDownBend:
Safe and sophisticated!*

Perfect material flow

The operator can place a stack of blanks next to the UpDownBend gauging system, pull the sheet into the machine, bend it and unload the finished part without lifting the workpiece. The load level, working plane and unload level are all the same height and allow perfect material flow without the assistance of a second operator. Optional “J” or “U” shape gauging systems perfectly support even the largest blanks.

*The UpDownBend:
Truly a One-Man-Show!*



Upper beam shape angles up

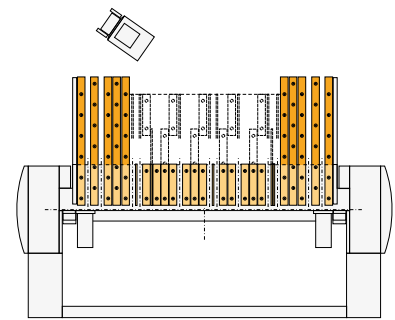
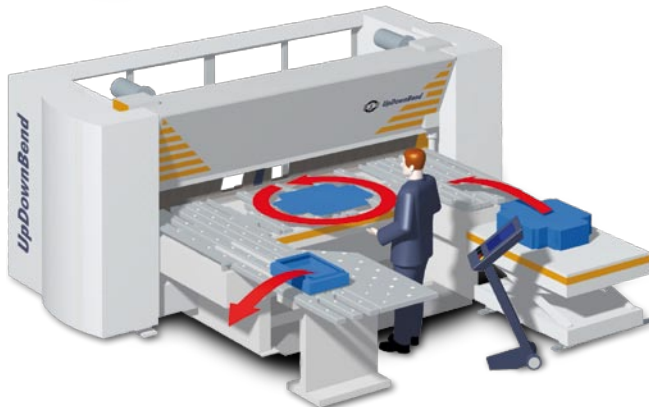

Standard backgauge system

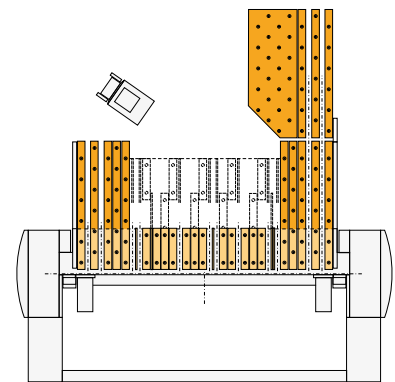

“J” shape gauging system
(left)

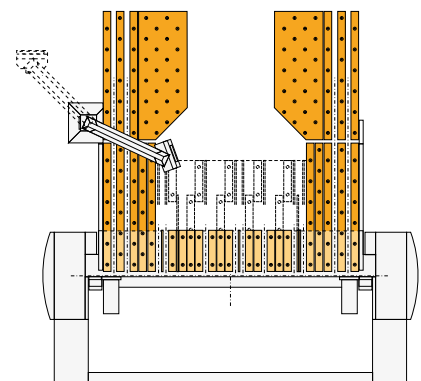

“U” shape gauging system
(Option: CNC on a pendant)

UpDownBend

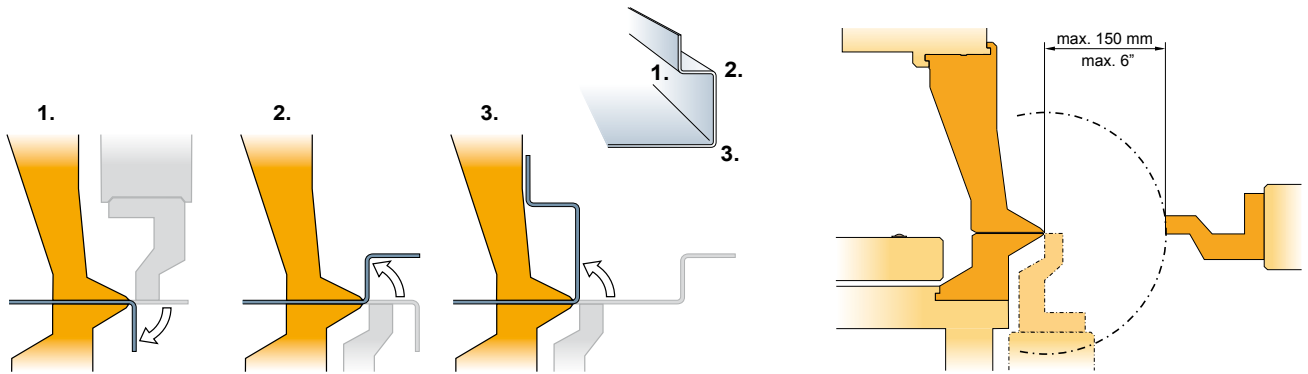

Folding sequence mostly from the outside in

Folding beam travel range when folding direction changes

Automated folding sequences

The UpDownBend forms the workpiece up and down, thus the operator can finish one side of the part completely before he turns the blank to the next side. With the up/down folding capability the folding sequence becomes simple and easy. As the gauging system moves the part forward and positions it for each fold, semi-automatic folding sequences can be performed.

The UpDownBend:
Simply higher productivity!



Special gauging system with stop fingers, that can be individually activated

Outstanding performance

Extremely rigid tools and a powerful drive system combine for an outstanding folding performance. An extremely rigid upper beam tool seat with double slot and key connection ensures that the tools are safely clamped. This guarantees the folding force to be perfectly supported regardless if it is coming from above or below.

The UpDownBend:
Top performance and perfect quality!



Upper beam tool seat with double slot and key connection

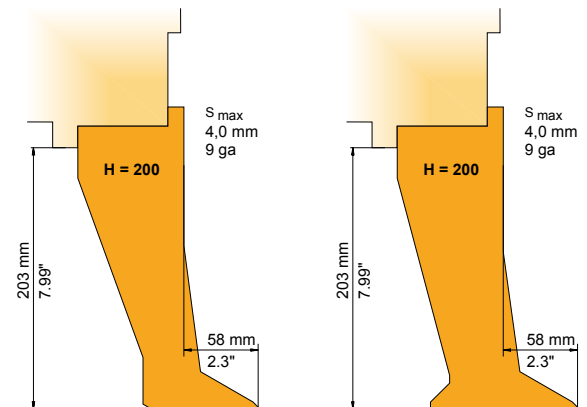

UpDownBend



The UpDownBend clamps the upper beam and folding beam tools automatically



Second monitor in the tool magazine



Tool magazine in machine stand

Simple tool change

The operator enters the front area of the machine only when changing tools. The UpDownBend clamps the upper beam and folding beam tools automatically. Place tools – Switch on – Off it goes!

Versatile upper beam tool segments, maximum 150 mm (5.92") wide with side gripping

pockets allow for an easy tool change.

The control graphically shows the operator which tool segments are required for the part length. An optional second monitor located in the tool storage magazine indicates the programmed tool positions in the tool change area.

The UpDownBend:
Short change-over times for small batch production!

Large free space

Precision-ground upper beam goats foot tools offer maximum front free space for deep C-flanges to be formed. High-tensile strength precision-ground folding beam tools are segmented and can be placed in two different directions in the folding beam tool clamping system. This turning option enhances part design capabilities.

The UpDownBend:
A class by itself!

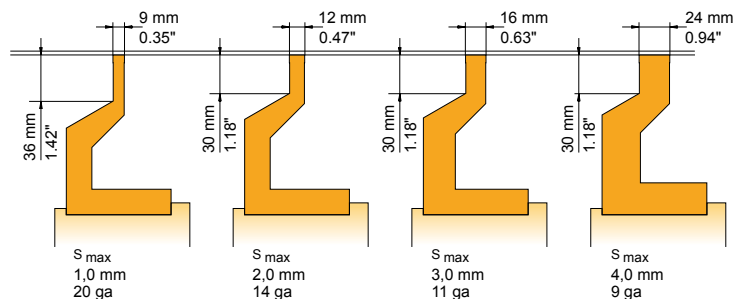
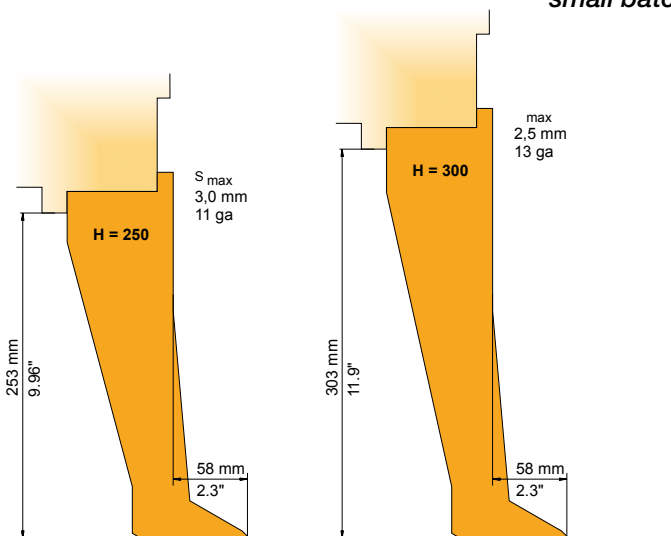

Tools for Upper Beam (left) und Folding Beam (above)

UpDownBend

Material thickness and bend radius adjustment

The pivot point setting system adjusts the UpDownBend automatically for the material thickness and the desired bend radius – when folding upward, as well as downward. The working plane always remains at the same height, even when the folding direction changes. Different material thicknesses and radii can be folded without tool changes.

*The UpDownBend:
Versatile! Great Investment!
Efficient!*

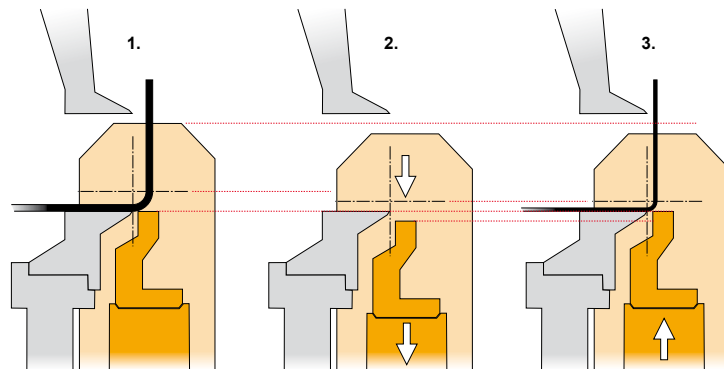

The pivot point setting system adjusts the UpDownBend automatically for the material thickness and bend radius

Extremely straight

RAS uses a revolutionary design structure for the folding beam. The beam-in-beam concept reduces folding beam deflection twenty-fold. Thus the UpDownBend achieves incredibly straight bends. Crowning systems are unnecessary, data input goes down and productivity goes up.

*The UpDownBend:
Outstanding innovation!*

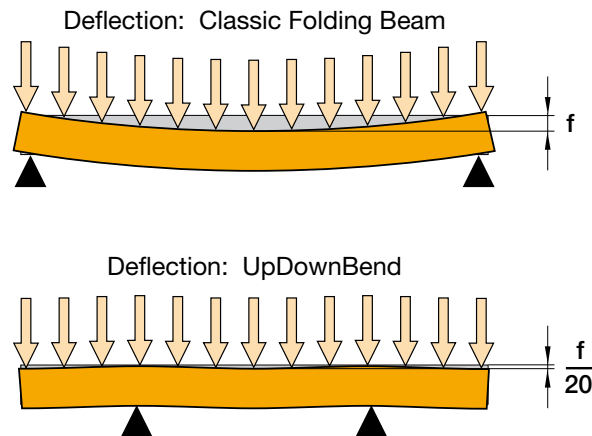

The beam-in-beam concept supersedes a crowning system

UpDownBend

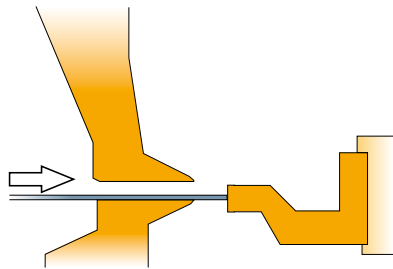
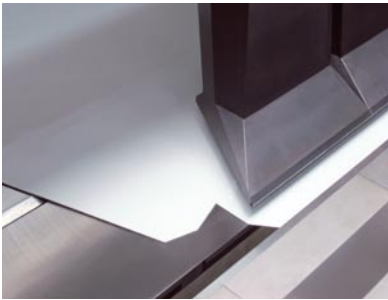

Useful on oblique parts: "folding beam as stop"

Folding beam as stop

The beam-in-beam concept eliminates a folding beam crowning system. This adds another important feature to the UpDownBend folding system. On a gauging system with parallel moving stop fingers oblique blanks (e.g. for trapezoidal parts) can only be positioned with extra effort. The control option "folding beam as stop" moves the folding beam to a 90 degree position. Now the surface of the folding beam tool can be used as a stop. The bending beam height axis positions the part within a 150 mm (5.9") travel range.

The UpDownBend:
Brilliant added value!



Glass sliding doors secure the folding area



Special gauging system: Visible safety light system

Safety first

The folding area is completely guarded by a glass sliding door. Thus the UpDownBend comes with a very compact floor space layout. Safety light systems and pressure bars inside the telescopic gauging system secure a safe operation.

The UpDownBend:
Safe and compact!

Draw and fold

With the revolutionary Touch&More control you can use your finger like a pencil. Simply paint a flange and size it with your finger to the correct dimension and angle. The CADalyzer simulates the folding sequence and automatically creates a part program using the part drawing. It shows the program, the finished part, and the actual bend sequence all at once. Simplicity also means: automatic blank calculation. The control displays graphic tool setup instructions to the operator and guides him through the program with simple handling instructions.

The UpDownBend:
Graphical! Understandable! Simple!

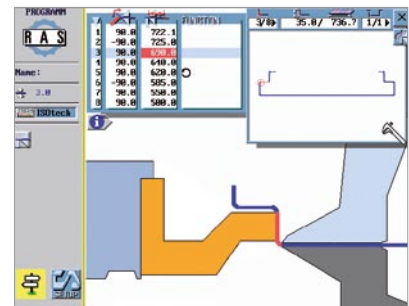

The CADalyzer simulates the folding sequence and programs the part



UpDownBend



Folding system

Technical Data	RAS 78.40		RAS 78.30	
Material Thickness max. (Mild Steel)	3.0 mm	11 ga.	4.0 mm	9 ga.
Material Thickness max. (Stainless Steel)	2.0 mm	14 ga.	2.5 mm	12 ga.
Material Thickness max. (Aluminum)	4.0 mm	9 ga.	5.0 mm	0.194"
Working Length	4060 mm	159.85"	3200 mm	126"
Gauging Depth (Rectangular)	95 - 1510 mm	3.75" - 59.5"	95 - 1510 mm	3.75" - 59.5"
Gauging Depth ("J" shape)	95-3270 (4150) mm	3.75" - 128.7" (163.4")	95-3270 (4150) mm	3.75" - 128.7" (163.4")
Gauging Depth ("U" shape)	95-3270 (4150) mm	3.75" - 128.7" (163.4")	95-3270 (4150) mm	3.75" - 128.7" (163.4")
Stop Finger Units (fix - telescope - fix)	2 + 10 + 2	2 + 10 + 2	2 + 8 + 2	2 + 8 + 2
Gauging System Accuracy	+/- 0.1 mm	+/- 0.004"	+/- 0.1 mm	+/- 0.004"
Open Height Upper Beam max.	600 mm	23.6"	600 mm	23.6"
Telescopic Gauging System (Travel Range)	640 - 1520 mm	25.2" - 59.8"	640 - 1520 mm	25.2" - 59.8"
Pivot Point Adjustment	+/- 15 mm	+/- 0.59"	+/- 15 mm	+/- 0.59"
Folding Beam Height Adjustment	150 mm	5.9"	150 mm	5.9"
Folding Beam Travel Range	180 deg	180 deg	180 deg	180 deg
Working Height	1000 mm	39.4"	1000 mm	39.4"
Machine Width	5550 mm	218.5"	4690 mm	185"
Machine Depth (Rectangular)	3000 mm	118.1"	3000 mm	118"
Machine Height (Upper Beam open)	2610 mm	102.8"	2600 mm	103"
Machine Height (Upper Beam closed)	2210 mm	87"	2200 mm	87"
Connected Power	15 kW	20.6 hp	15 kW	20.6 hp
Air Pressure	6 bar	80 PSI	6 bar	80 PSI
Weight	12,000 kg	26,500 lbs	10,000 kg	22,000 lbs
Speeds				
Upper Beam	75 mm/s	2.95"/s	75 mm/s	2.95"/s
Folding Beam	110 deg/s	110 deg/s	110 deg/s	110 deg/s
Gauging System from min to max	2.2 s	2.2 s	2.2 s	2.2 s

RAS Reinhardt Maschinenbau GmbH
 Richard-Wagner-Str. 4-10
 71065 Sindelfingen · Germany
 Tel. +49-7031-863-0
 Fax +49-7031-863-185

www.RAS-online.de
Info@RAS-online.de

Modifications reserved. Pictures may show options.