

INNOVATION MADE IN GERMANY

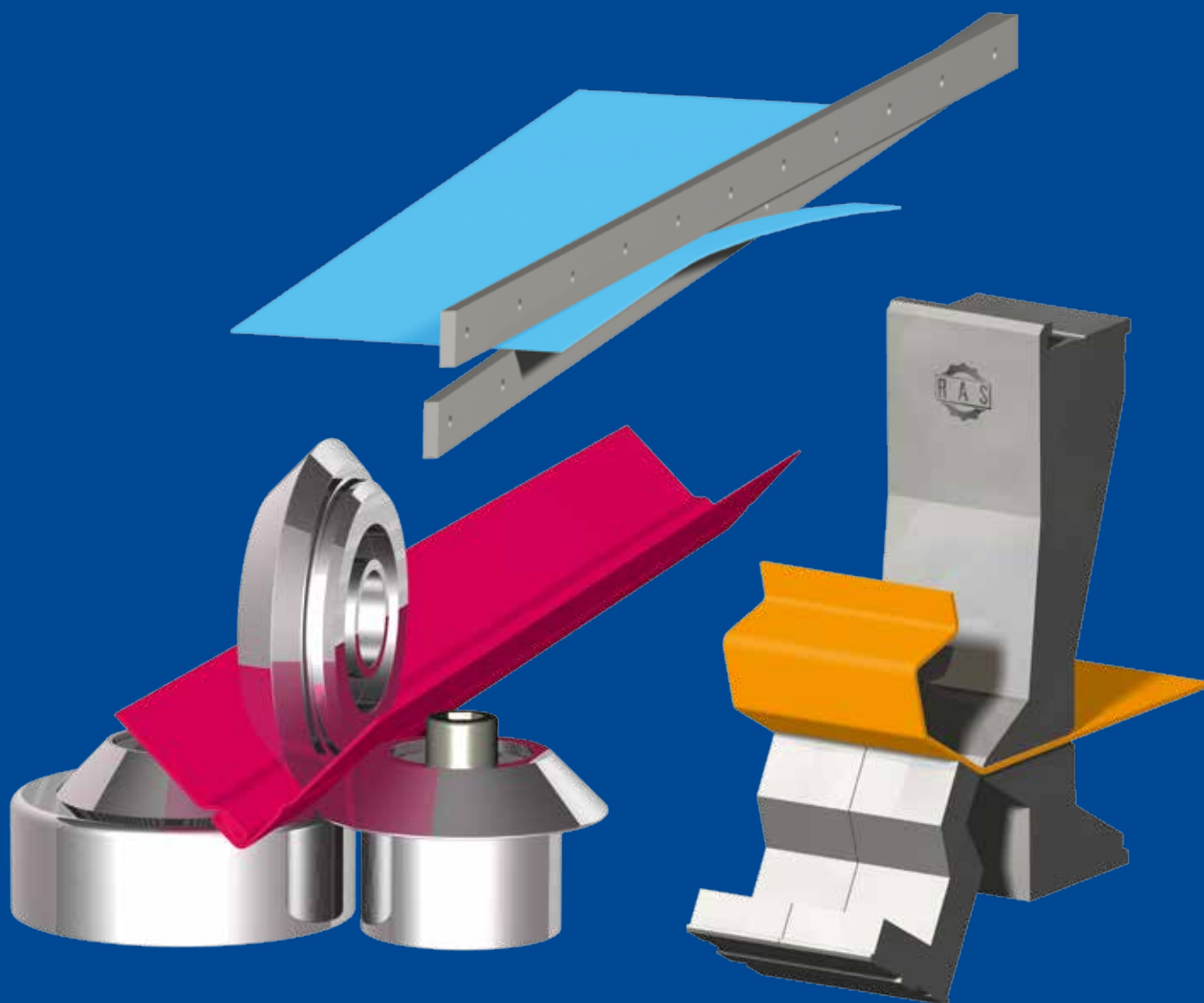

Production Program



CUTTING

BENDING

FORMING

SOFTWARE

Folding

Frequently changing parts and small batch sizes require a universal bending technology. The most common bending techniques are press brake bending and folding. On a press brake the punch moves into the die. The blank located between the tools will be bent. On a folding machine the sheet is placed on a table.

A gauging system positions the part to the bend line. The upper beam and lower beam clamp the material. During the bending cycle the folding beam moves up around a pivot point. For machines equipped with bi-directional bending, the folding beam can either move up or down depending on the bending direction.

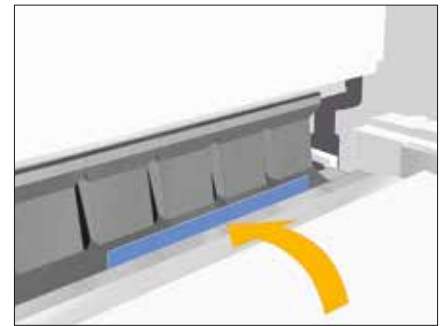
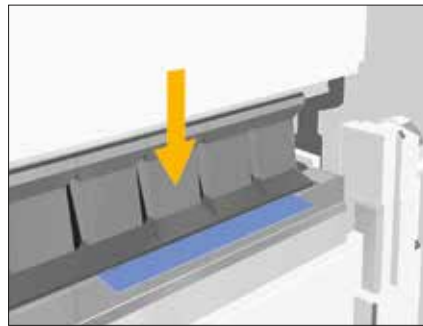
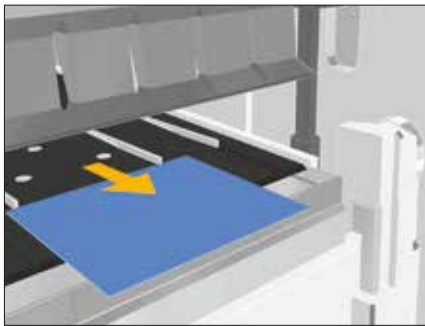

Folding sequence: Position blank - clamp - bend.

Handling

The long flange of the part remains on the support table. As a result, folding is significantly faster, particularly for large parts. Additional bending supports are not needed. At the same time, folding is also safer as the operator is not in touch with the part during clamping and bending.

Even large workpieces can be handled by one person. Folding therefore is a very cost efficient bending method. If the bending direction changes on a large panel, folding machines are available that can bend in both directions (up/down).

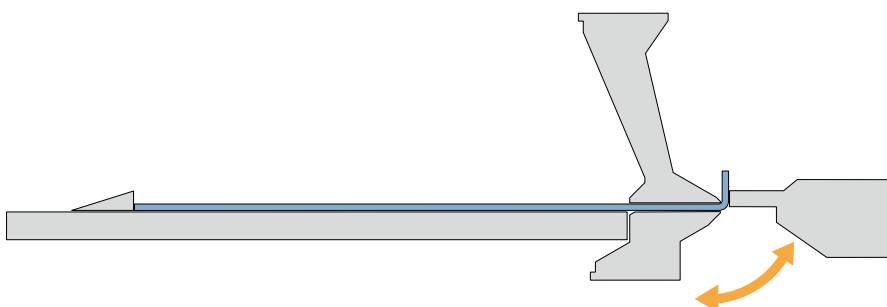

The long flange of the part remains on the support table - the short flanges are bent.



Easy handling even of large parts by only one person.

Number of tools / Tool changes

Folding machines can bend any angle with a single tool. The machine automatically adjusts to the sheet thickness. The universal tools reduce the setup times as well as the investment and operating costs. Advanced automated folding machines come with an automatic tool changer.

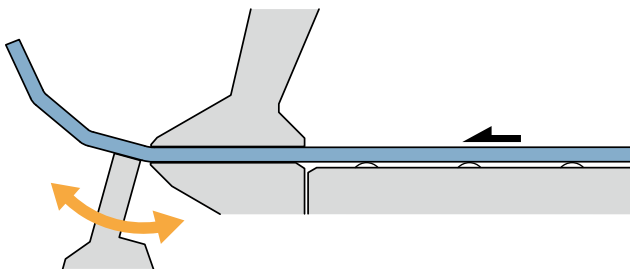

Sensitive material surfaces

Folding reduces the sliding of tools against material surfaces to a minimum, or completely eliminates it on some machines (Multibend-Center, ProfileCenter). You will find no scratches on the material surface - ideal for stainless steel or coated sheets.

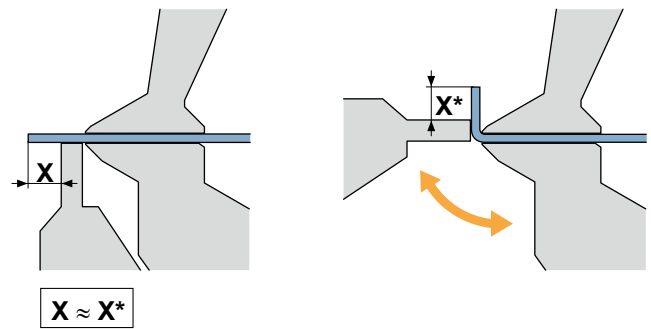

Bending radii

A radius can easily be created using a folder with small bending steps. By using small steps the outside of the radius will be very smooth and the individual steps will not be visible.

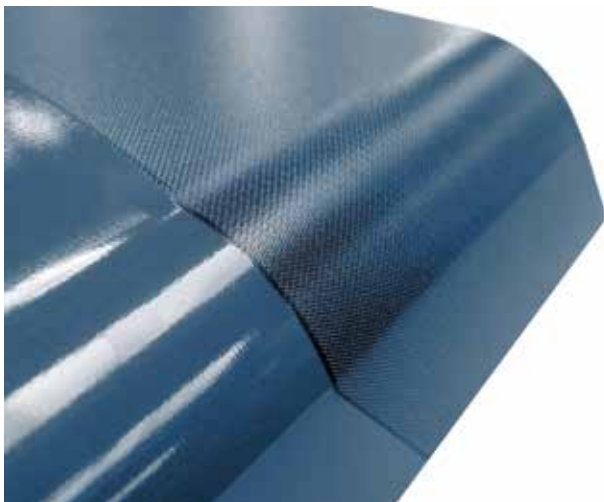

Tool wear

As there are only very slight relative movements between the tool and the material surface, the tooling shows no abrasion wear even after years of use.

Bending hems

Folding does not require special tools for hemming. Open or closed hems can be created.

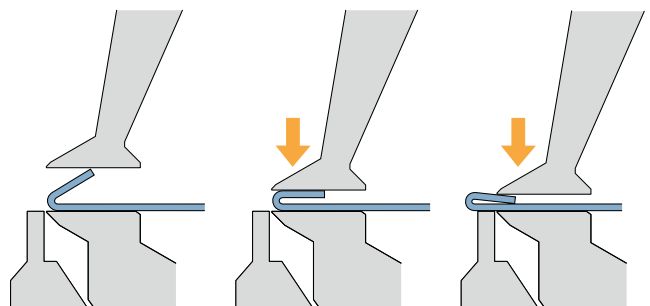

Influence of sheet thickness tolerances

With folding technology, the folding beam tools touch the outside of the material and move exactly to the programmed angle. This angle reference is only on the outside of the material. As a result, sheet thickness tolerances do not affect the bend angle or the repeatability.

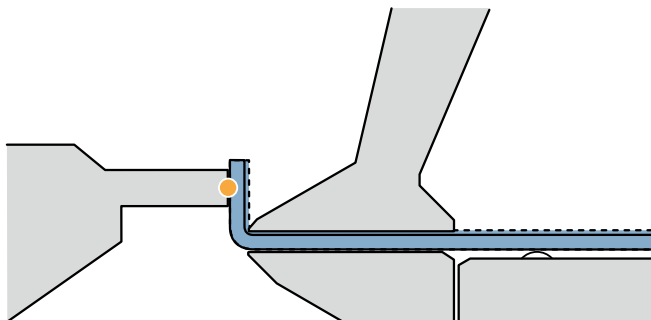

Influence of the gauging method

On a folding machine the entire part is inside the machine. Only a short flange stands out of the upper and lower beam tool. A folder gauges the part instead of the flange. Blanks tolerances disappear in the first flange. The area dimension and the opposite flanges are always accurate.

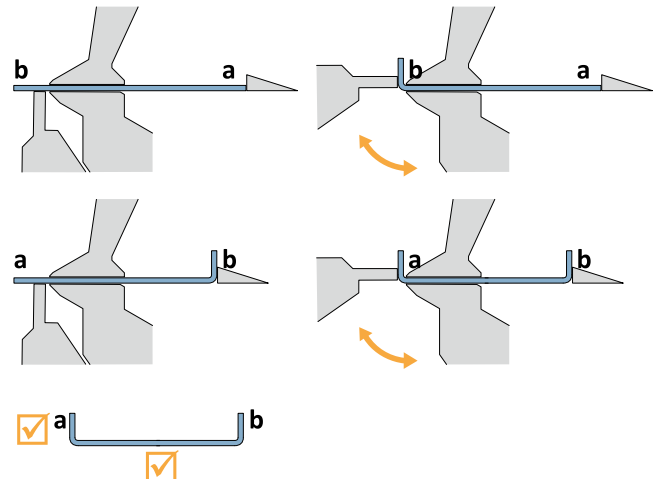

Symbols



Machine bends up.



Machine bends up and down (UpDown technology).



The machine bends open ended profiles.



The machine bends profiles and boxes/panels.



The software programs the part automatically and recommends the best bending strategy with a 5-star ranking. The bending process is shown in a 3D simulation. Bending 4.0 realized!



The software allows the programming of the part assisted by a 3D simulation.



The machine has an automatic tool changer.

						Page
	Multibend-Center	3060 x 2.0 mm 2560 x 2.0 mm 2160 x 2.0 mm	 	 		8
	UpDownCenter	4060 x 2.5 mm 3200 x 3.0 mm	 	 		12
	XLTbend	4060 x 2.5 mm 3200 x 3.0 mm	 	 		14
	UpDownBend	4060 x 3.0 mm 3200 x 4.0 mm	 			16
	GIGAbend	4060 x 5.0 mm 3200 x 6.0 mm	 			18
	FLEXIbend	4060 x 2.5 mm 3200 x 3.0 mm	 			20
	TURBObend plus	3200 x 2.0 mm 2540 x 2.5 mm	 			22
	MiniBendCenter	50 x 40 600 x 600 x 3.0 mm	 	 		24
	ProfileCenter	3200 x 2.0 mm	 	 		26
	XXL-Center	8480 x 1.5 mm 6400 x 1.5 mm 4240 x 1.5 mm	 	 		28
	XL-Center	3200 x 1.5 mm	 	 		30
	TURBObend	3150 x 1.5 mm	 			32

Cutting

Swing beam shears are machine tools that perform straight cuts on sheet metal. On a swing beam shear the upper blade moves in a circular arc. The rigid design of the shear and the extremely low rake angle ensure that blanks as small as 10 to 15 x material thickness remain flat after cutting.

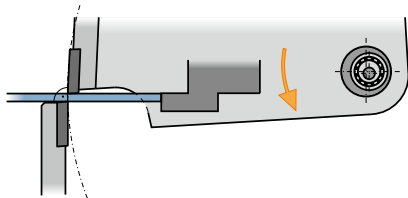

The upper blade penetrates the metal sheet above the lower blade and supplies clean, right-angled cuts with almost no burr.

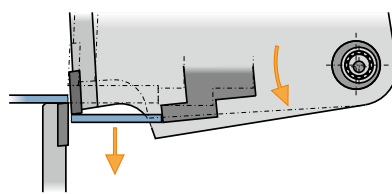

The pivoting movement of the swing beam prevents the blank from jamming between the lower blade and the backstop.

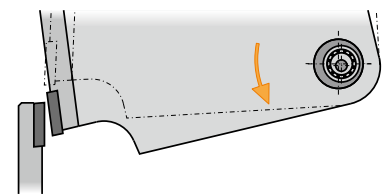

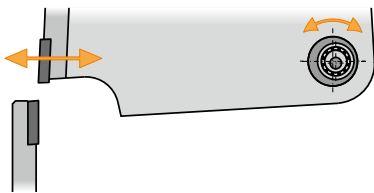

The upper blade moves away from the lower blade after cutting. This keeps the blade sharp for a long time.



The cutting gap can be easily adjusted by simply turning the cutting gap eccentric.

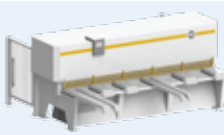

Our innovative swing beam cutting technology guarantees clean, straight, dimensionally accurate and rightangled cuts.

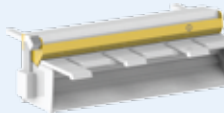
			Page
	POWERcut	4040 x 5.0 mm 3190 x 6.3 mm	34
	PRIMEcut	3100 x 3.0 mm	36
	SMARTcut	3100 x 2.0 mm 2540 x 2.0 mm	37

Forming

				Page
	Swaging machines EasyFormer	400 x 3.00 mm 255 x 1.75 mm		38
	Swaging machines 11.15 – 11.35	200 x 1.25 mm		40
	Flanging machine 21.20	1.5 mm		41
	Ducting machines DuctZipper-V	140 ² x 1.25 mm 100 ² x 1.00 mm		42
	Ducting machines DuctZipper-L	140 ² x 1.25 mm 100 ² x 1.00 mm		43
	Roll Forming Machines SpeedySeamer	1.5 mm		44
	Rounding machine VENTrrounder	1500 x 1.25 mm		45
	Seam Closing Machine 25.15	1520 x 0.88 mm		46

Bending Centers

Multibend-Center

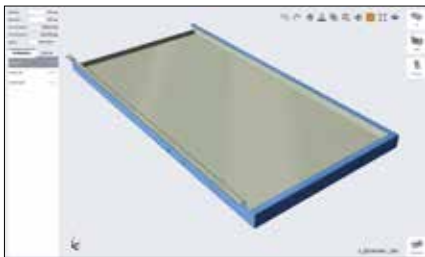

Office software with one-click programming starting from a STEP, DXF, GEO file of the part. No expert knowledge required. Fast, safe, precise.



The best bending sequences are shown according to the highest the 5-star ranking.



The 3D simulation shows the folding sequence and possible collisions. New products can already be evaluated during the design process.



The Multibend-Center is characterized by speed and high productivity levels.



Fully automatic bending sequences: positioning, rotation, bending, and tool change.

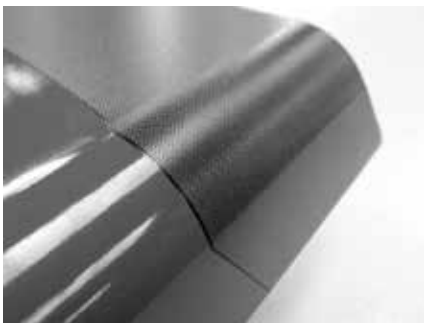

Scratch-free bending of sensitive materials. No tool wear.



Due to highest levels of precision and repeatability, the parts are suitable for laser welding.



Four-sided boxes can be as tall as 203 mm.

Bending Centers

Loading and unloading

In addition to manual loading and unloading, there are a variety of options for automatic loading and unloading of the machine. Depending on the requested degree of automation and the manufacturing conditions, the handling systems on the loading and unloading side can be individually configured.

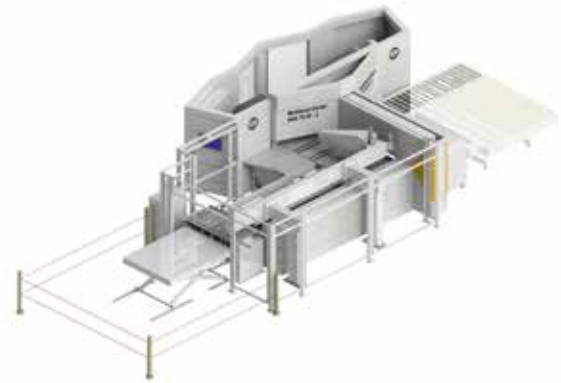

Multibend-Center with MiniFeeder loading component. Blanks are supplied on a scissor table.



Automatic program loading can be added to the MiniFeeder or gantry loader by scanning a barcode or QR code label on the blank.

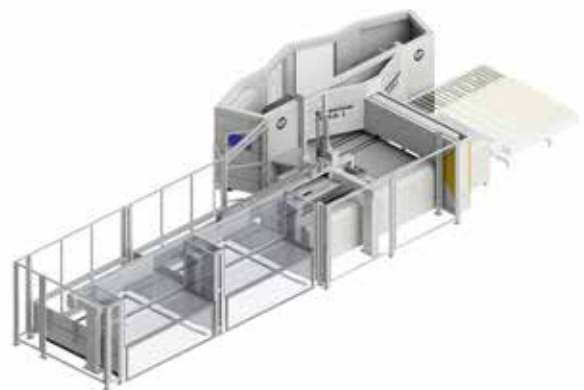

Multibend-Center with single or double station gantry loader.



Multibend-Center with robot loading. Provision of the blanks on Euro-pallets. The robot can also flip the blanks. Intelligent robot: No programming or teaching required.

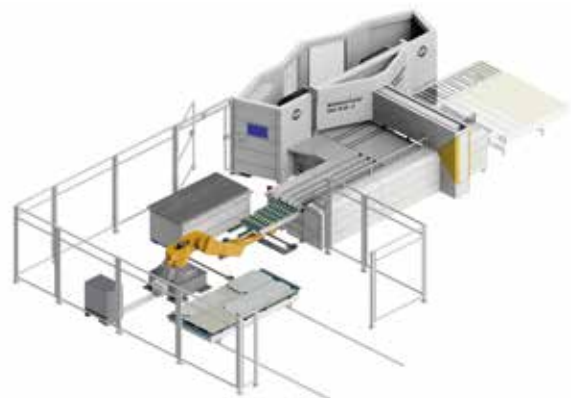

Multibend-Center with robot loading. Blanks supplied from a storage system. The robot can also flip the blanks. Intelligent robot: No programming or teaching required.



Suction frame of the gantry loader with 6 suction cups used to peel up the blank and 45 freely moveable suction cups.

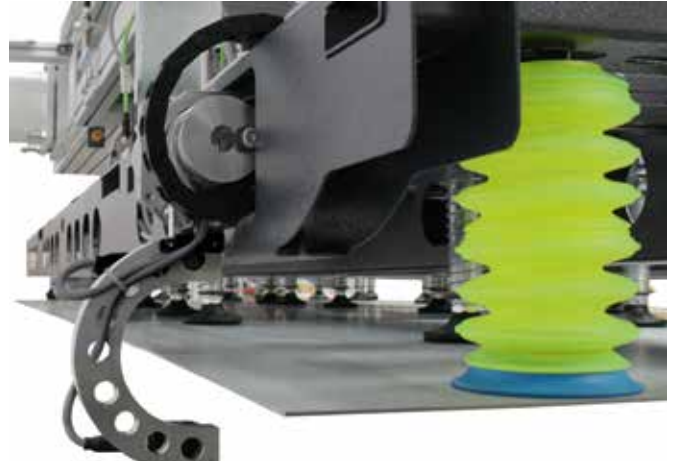

Touchless double sheet detection arm on the suction frame after lifting of the blank.

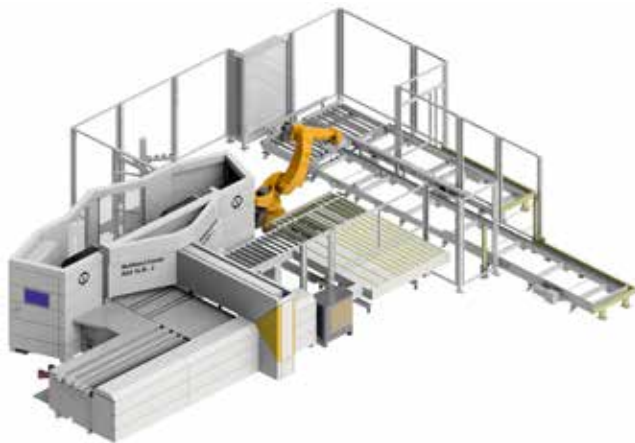

Multibend-Center with manual part unloading via finished part buffer or automatically by intelligent robot. Rotation station for finished parts. Provision of the pallets by U-shaped pallet station.

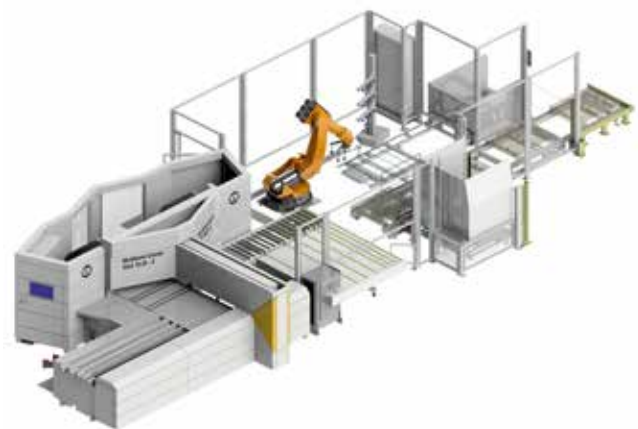

Multibend-Center with manual part unloading via finished part buffer or automatically by intelligent robot. Rotation station for finished parts. A pallet magazine provides pallets. Back panel magazine provides back panels for vertical stacking, the robot attaches them automatically to the pallet.

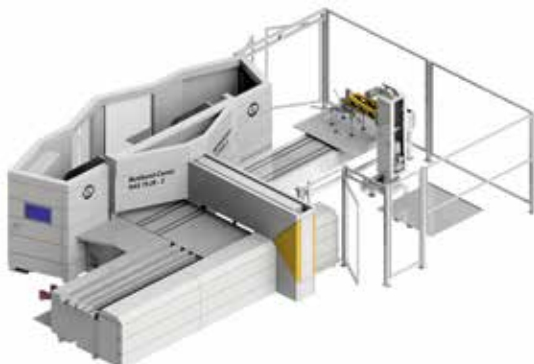

Multibend-Center with automatic part unloading by a gripper station.

Technical data	Bending length max.	Sheet thickness max.	Box height max.
Multibend-Center RAS 79.31-2	3060 mm	2.0 mm	203 mm
Multibend-Center RAS 79.26-2	2560 mm	2.0 (2.5) mm	203 mm
Multibend-Center RAS 79.22-2	2160 mm	2.0 (2.5) mm	203 mm

Bending Centers

UpDownCenter

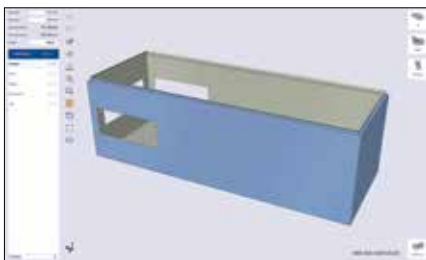

Office software with one-click programming starting from a STEP, DXF, GEO file of the part. No expert knowledge required. Fast, safe, precise.



The best bending sequences are shown according to the highest the 5-star ranking.



The 3D simulation shows the folding sequence and possible collisions. New products can already be evaluated during the design process.



Automatic part positioning by a suction gauging system.



High flexibility in handling due to front suction cups and small part suction cups.



Upper beam tools for boxes up to 400 mm tall.



The automatic tool changer places the tools of the upper beam in position.

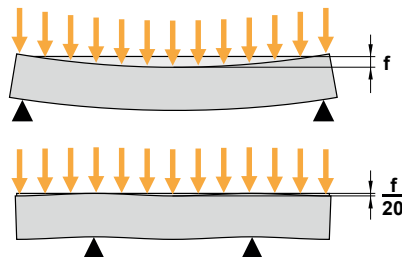

Maximum bending accuracy due to the patented beam-in-beam folding beam design.

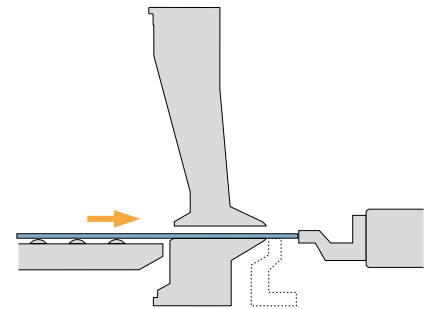

Extended flexibility, as the folding beam can be used as a gauging stop.



Accurate alignment of long and narrow parts with the active squaring arm.



Technical data	Bending length max.	Sheet thickness max.	Box height max.
UpDownCenter RAS 78.43	4060 mm	2.5 mm	400 mm
UpDownCenter RAS 78.33	3200 mm	3.0 mm	400 mm

Folding Machines

XLTbend

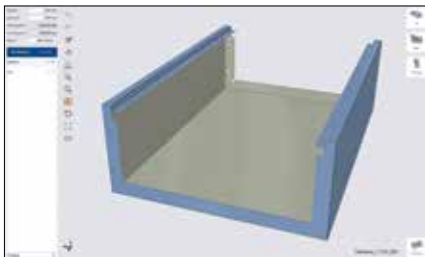

Office software with one-click programming starting from a STEP, DXF, GEO file of the part. No expert knowledge required. Fast, safe, precise.

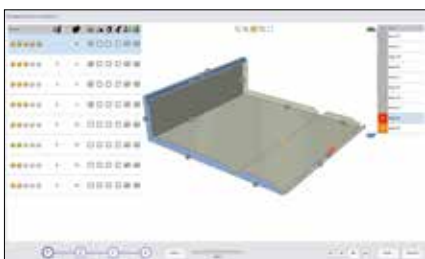

The best bending sequences are shown according to the highest the 5-star ranking.

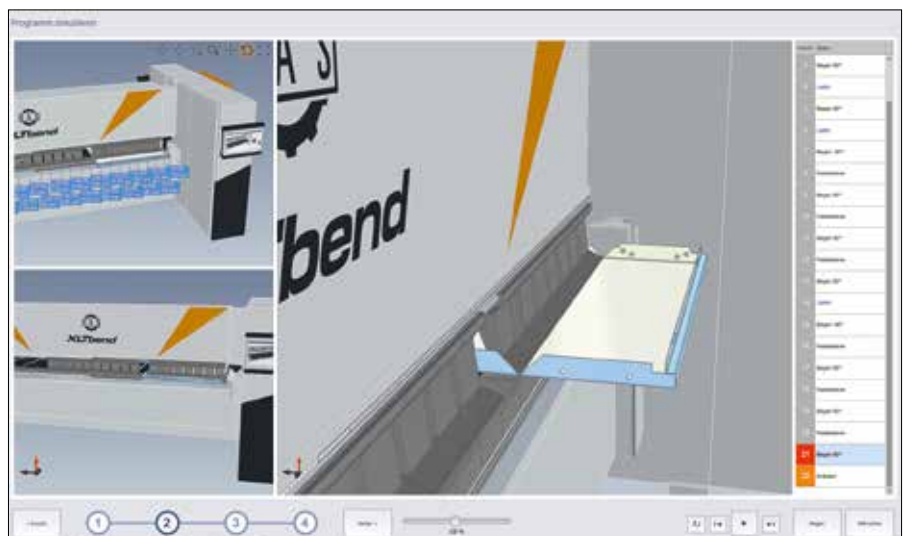

The 3D simulation shows the folding sequence and possible collisions. New products can already be evaluated during the design process.

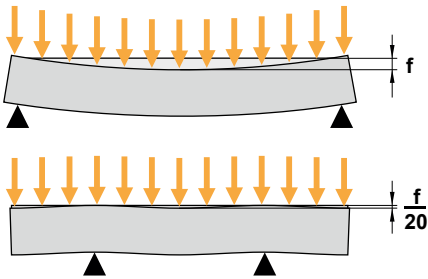

Maximum bending accuracy due to the patented beam-in-beam folding beam design.

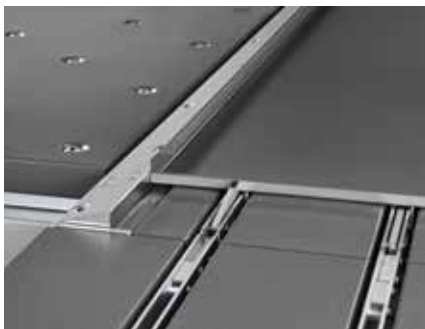

Accurate alignment of long and narrow parts with the active squaring arm.

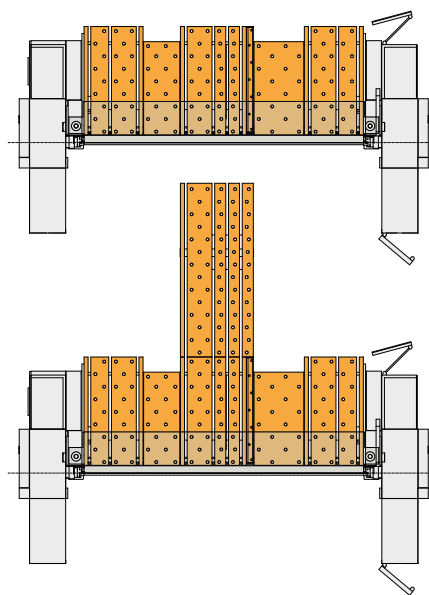

Rectangular and T-shape gauging system

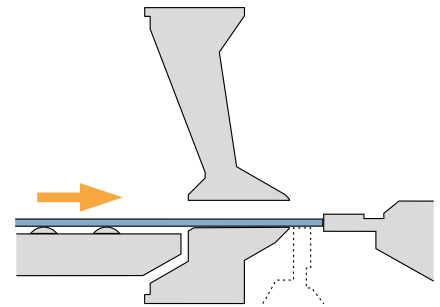

Extended flexibility, as the folding beam can be used as a gauging stop.

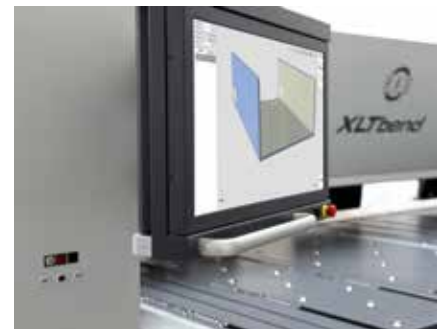

Control monitor on gauging system side

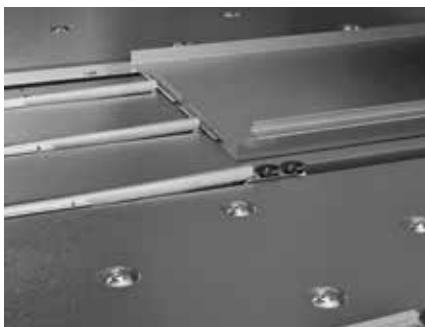

The suction cups of the hybrid gauging system hold the part through a sequence of bends to the stop fingers.



If the outside edges of the blank are not straight, individual stop fingers can be deactivated.

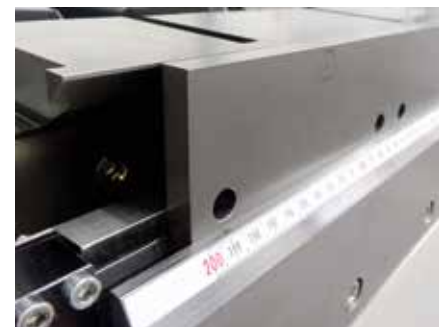

Quick tool change: Place upper and folding beam tools according to setup instructions ... they will be clamped automatically.

Technical data	Bending length max.	Sheet thickness max.
XLtbend RAS 71.40	4060 mm	2.5 mm
XLtbend RAS 71.30	3200 mm	3.0 mm

Folding Machines

UpDownBend



Gauging system extended to its maximum dimension.



Gauging system retracted to its minimum position.





Tall upper beam tools allow the production of deep boxes.

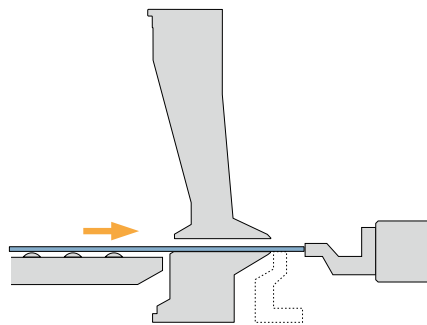

Extended flexibility, as the folding beam can be used as a gauging stop.

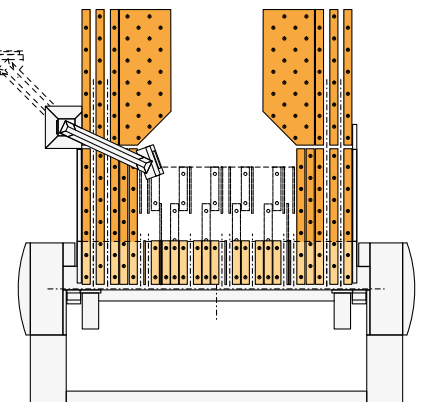
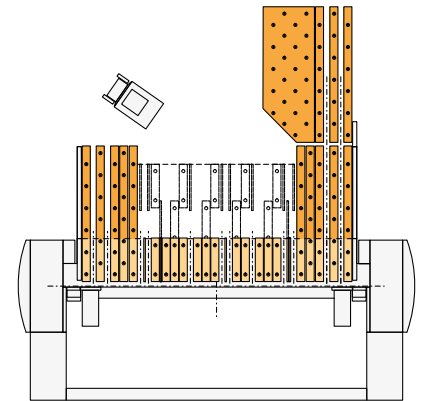
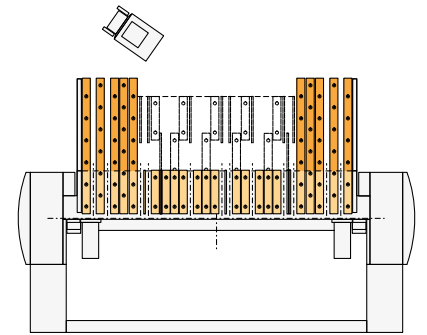

Flexible part positioning. Individual stop fingers can be deactivated.



Folding beam in 180 degree position

Gauging system variations.



Technical data	Bending length max.	Sheet thickness max.
UpDownBend RAS 78.40	4060 mm	3.0 mm
UpDownBend RAS 78.30	3200 mm	4.0 mm

Folding Machines

GIGAbend



Tall upper beam tools used for deep boxes (500 mm opening height).

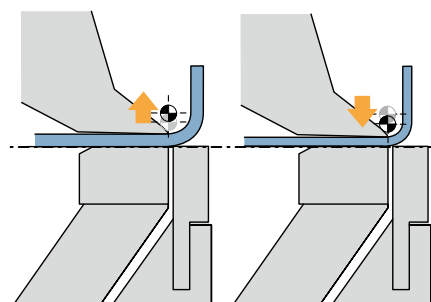

Automatic adjustment of machine to sheet thickness and bend radius.

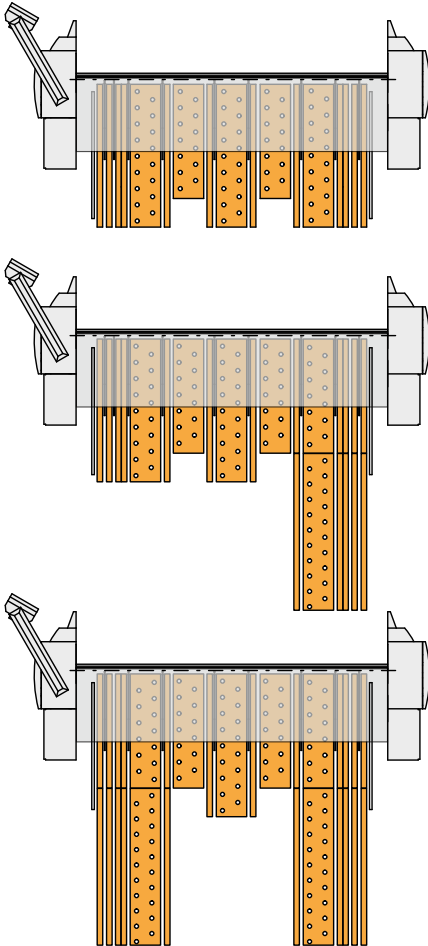

Gauging system options: rectangular, J, and U shape.



Part design flexibility due to slim but rigid tools.



Upper beam tool with large front free space.



Optional digital display for folding beam adjustment.



The PowerBooster clamps the blanks with 120 tons of pressure to guarantee straight bends.



During the folding sequence the sheet rests on the machine table. No need to lift the part.



Quick tool set-ups due to the automatic tool clamping system.



At the same time, the PowerBooster offers impressive performance when hems need to be closed.

Technical data	Bending length max.	Sheet thickness max.
GIGAbend RAS 76.40	4060 mm	5.0 mm
GIGAbend RAS 76.30	3200 mm	6.0 mm

Folding Machines

FLEXIbend



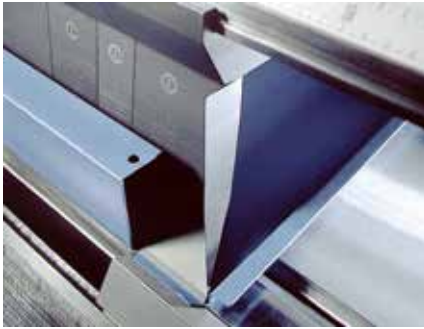

Bend tabs with segmented folding beam tools.



Part design flexibility due to slim but rigid tools.



Optional digital display for the folding and lower beam adjustment.

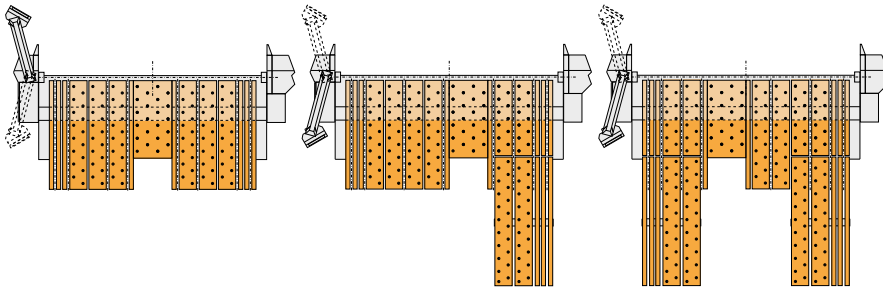

In addition to the rectangular gauging system, optional „J“ and „U“ shapes can be configured.



Part lined up with the squaring arm.



Technical data	Bending length max.	Sheet thickness max.
FLEXibend RAS 73.40	4060 mm	2.5 mm
FLEXibend RAS 73.30	3200 mm	3.0 mm

Folding Machines

TURBObend plus



Control panel on an arm



Sheet support tables with ball casters



Upper beam with sharp tools



Segmented upper beam tools with front free space

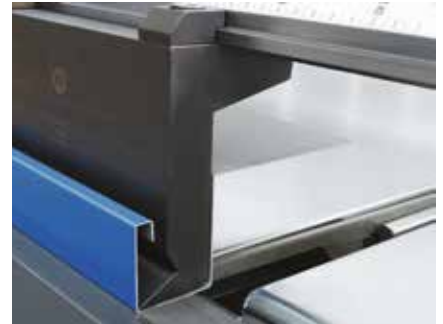

Segmented upper beam tools with rear free space



Tools with quick clamping system



Setting the CrownTool for crowning on the folding beam.



Rear of the TURBObend plus with rectangular gauging system

Technical data	Bending length max.	Sheet thickness max.
TURBObend plus RAS 62.30	3200 mm	2.0 mm
TURBObend plus RAS 62.25	2540 mm	2.5 mm

Bending Centers

MiniBendCenter

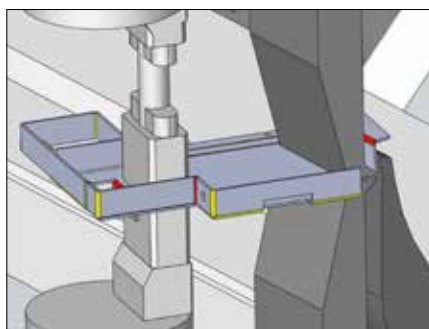
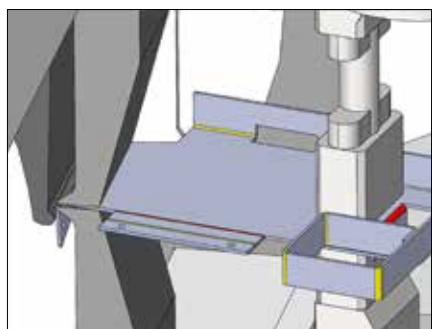

Simple to use Office software starts from a STEP file of the part with 3D visualization of the bending processes.

Fully automatic up and down bending with a maximum sheet thickness of 3 mm.



The RAS MiniBendCenter is the world's only folding center for small parts. The blanks are automatically loaded, aligned and squared. Tool setup is automatic.

The automatic tool setup allows for quick change-over between parts and the production of small batch sizes.



Robotic loading offers maximum flexibility. Blanks can be loaded from a bulk material box or from stacks.



Measuring the parts by a laser scanner.



Several bending stations can be setup along the length of the machine. Complex parts can be completed in a single run.



Highest levels of precision and repeatability



Dedicated unloading of the finished parts depending on floor space conditions, material flow, and sensitivity of the parts.



Unloading of finished parts into bulk material containers.

Technical data	Sheet thickness max.	Blank size min.	Blank size max.
MiniBendCenter RAS 79.05	3.0 mm	50 x 40 mm	600 x 600 mm

Bending Centers

ProfileCenter

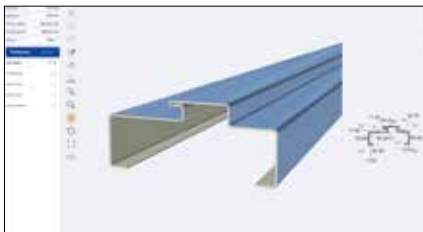

Office software with one-click programming starting from a STEP, DXF, GEO file of the part. No expert knowledge required. Fast, safe, precise.

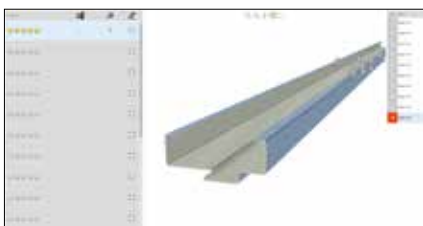

The best bending sequences are shown according to the highest the 5-star ranking.

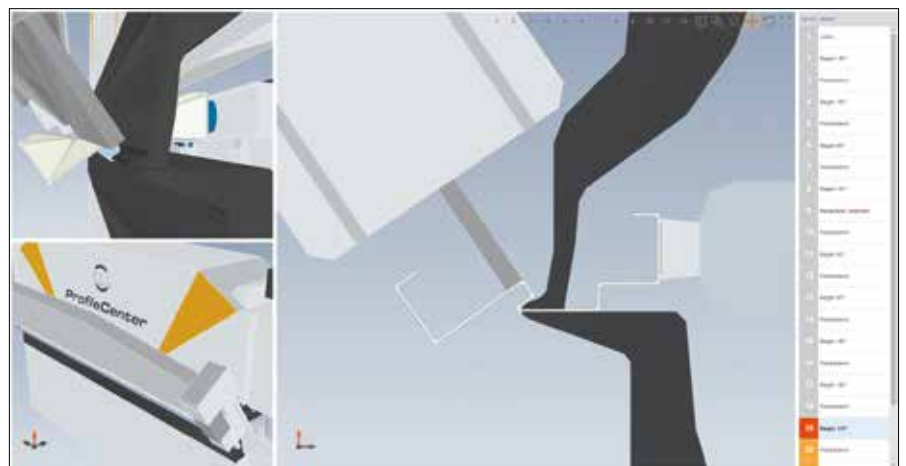

The 3D simulation shows the folding sequence and possible collisions. New products can already be evaluated during the design process.



Secured bending accuracy due to automatic alignment of the supplied blanks.



Complex geometries can be bent due to the large free space around the tools.

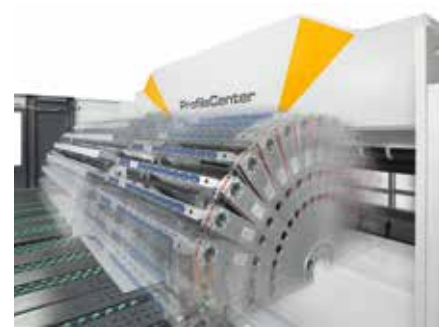

Automatic bending with fast cycle times. The workpiece does not have to be positioned at the stops during bending process.

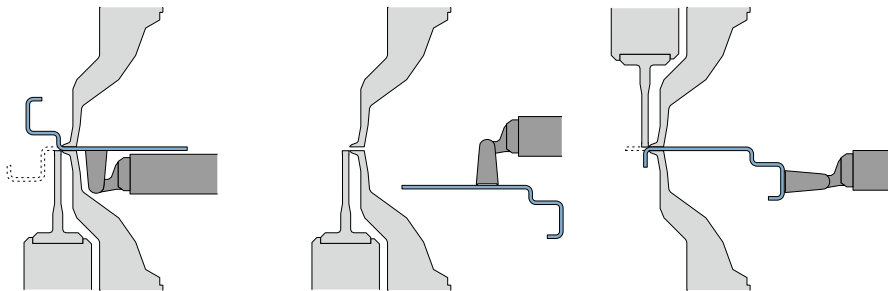

Automatic bending of complex profiles without operator intervention. The unique FlexGripper handling system automatically changes its gripping position when needed.



Scratch-free bending of pre-coated or galvanized sheets as well as of stainless steel as the folding beam tool rolls away with the flange.

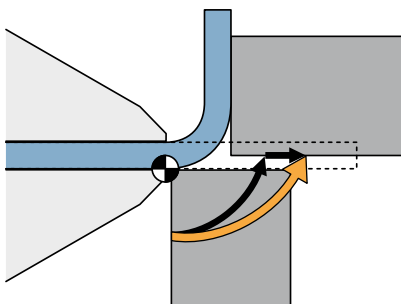

Folding beam movement for scratchfree bending.



Precise flange dimensions, angles and straightness of the profiles.



Batch size 1 production is possible as the machine automatically adapts to changing sheet thicknesses and material types.

Technical data	Sheet thickness max.	Blank size min.	Blank size max.
ProfileCenter RAS 79.30	2.0 mm	100 x 600 mm	700 x 3200 mm

Bending Centers

XXL-Center

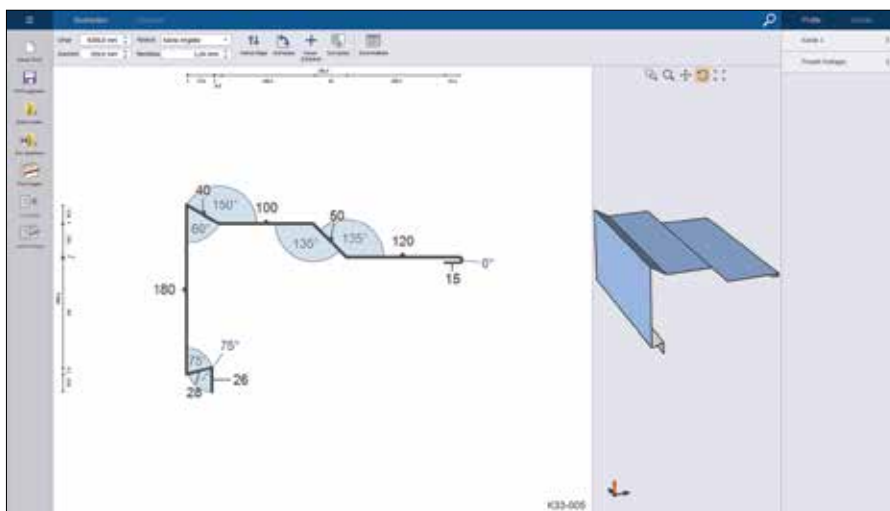

If several bending sequences are possible, the software proposes the best option with a 5-star ranking.



2D or 3D simulation of the bending sequences and visualization of possible collisions.

Drawing of a profile on the touchscreen monitor. Automatic programming of the bending sequence with just one mouse click. No expert knowledge required. New profiles can already be evaluated in the office.



Retractable table sections for easy blank loading and flipping.

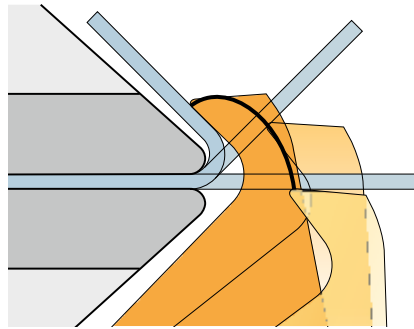

Scratch-free bending of pre-coated materials as the folding beam tool rolls away from the flange.

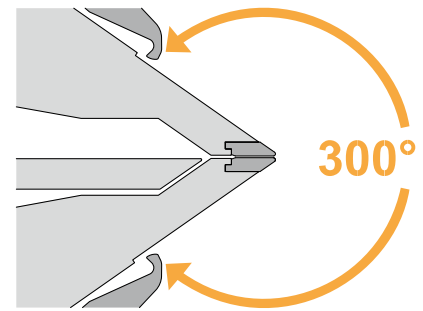

Many parts geometries can be bent due to a 300 degree free space in front of the folding beam (patented).



CutModule for trimming wide blanks. Automatic sequence: cutting and bending.



Secured bending accuracy due to automatic alignment of the blanks.



Grippers position the part. This ensures precise flange dimensions and fast bending sequences.

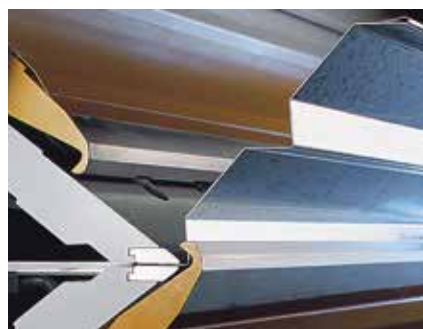

No part rotation required since the machine bends up and down. High productivity due to fast bending cycles.



Technical data	Bending length max.	Sheet thickness max.	Backstop
XXL-Center RAS 75.08-2	8480 mm	1.5 mm	12 - 750 mm
XXL-Center RAS 75.06-2	6400 mm	1.5 mm	12 - 750 mm
XXL-Center RAS 75.04-2	4240 mm	1.5 mm	12 - 750 mm

Bending Centers

XL-Center

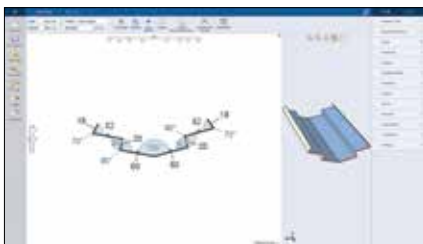

Drawing of a profile on the touchscreen monitor. Automatic programming of the bending sequence with just one mouse click. No expert knowledge required. New profiles can already be evaluated in the office.



If several bending sequences are possible, the software proposes the best option with a 5-star ranking.

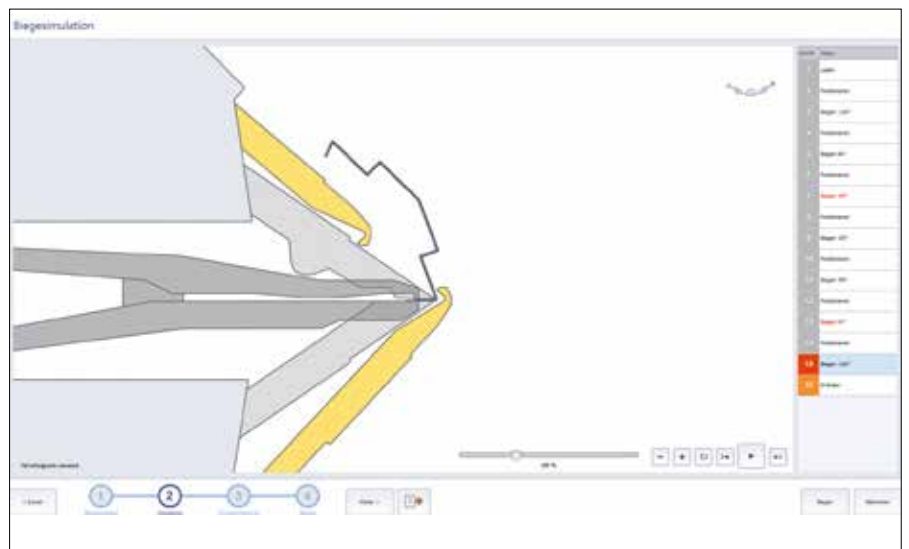

2D or 3D simulation of the bending sequences and visualization of possible collisions.

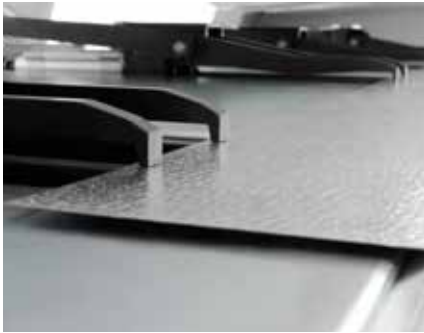

Grippers position the part. This ensures precise flange dimensions and fast bending sequences.

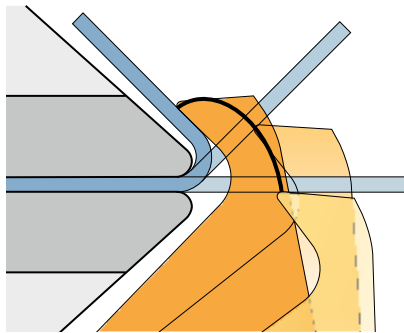

Scratch-free bending of pre-coated materials as the folding beam tool rolls away from the flange.

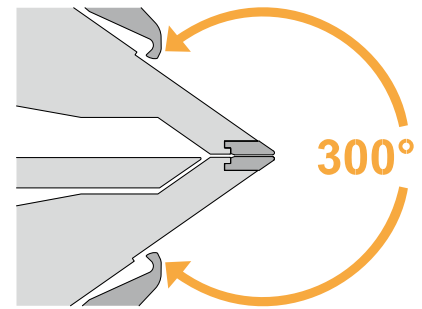

Many parts geometries can be bent due to a 300 degree free space in front of the folding beam (patented).



No part rotation required since the machine bends up and down. High productivity due to fast bending cycles.

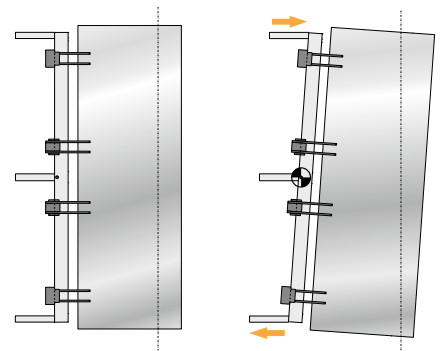

The gauging system can produce automatically tapered parts.



No programming required for accurate and perfectly interlocking profiles (tapered parts).

Technical data	Bending length max.	Sheet thickness max.	Backstop
XL-Center RAS 63.30	3200 mm	1.5 mm	6.5 - 750 mm

Folding Machines

TURBObend

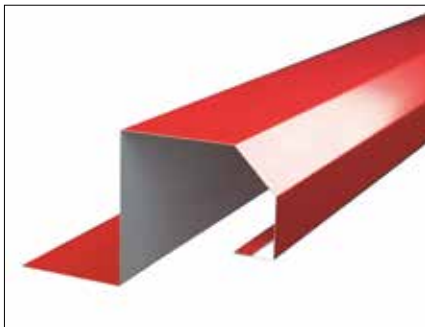

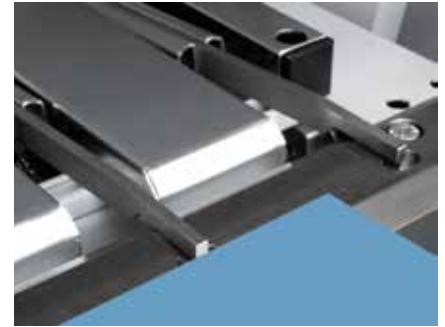

Automatic folding beam adjustment for thin and thick materials.

Stop finger at minimum stop dimension

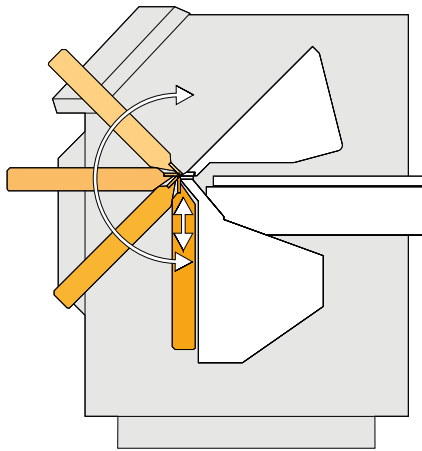

Rear of the TURBObend with rectangular gauging system.

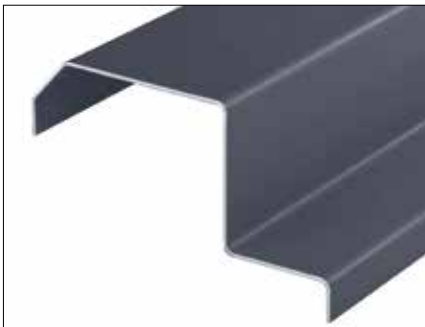

Technical data	Bending length max.	Sheet thickness max.	Backstop
TURBObend RAS 61.31	3150 mm	1.5 mm	6.0 - 1000 mm

Swing Beam Shears

POWERcut

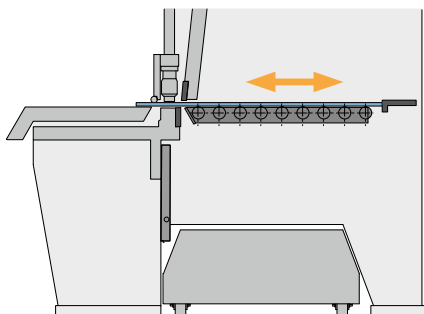

The sorting and sheet support system holds the blank flat before the cut. This eliminates the material from hanging down and guarantees for perfect cutting dimensions.

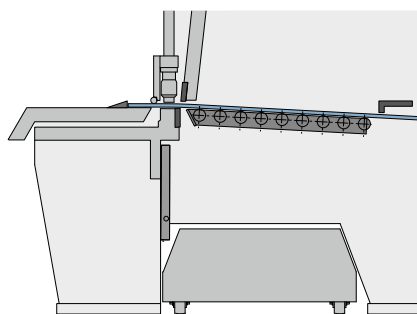

Extra long sheets can be cut while passing underneath the backgauge. The backgauge moves to its maximum dimension and the sheet support moves slightly downward.

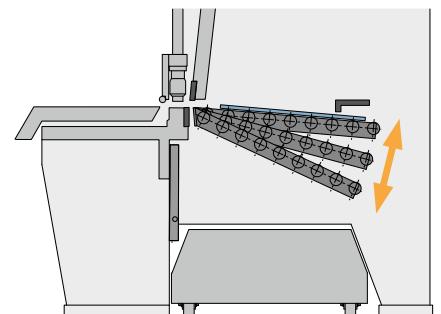

After the cut is made, the sheet support system can tilt to three different angles. Even small strips of 40 mm can slide down quietly and gently.

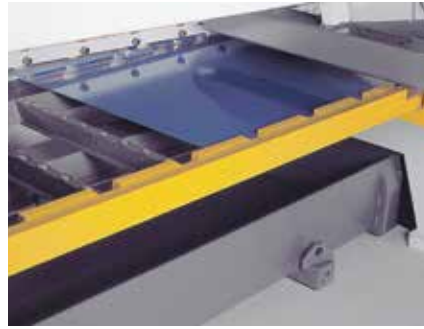
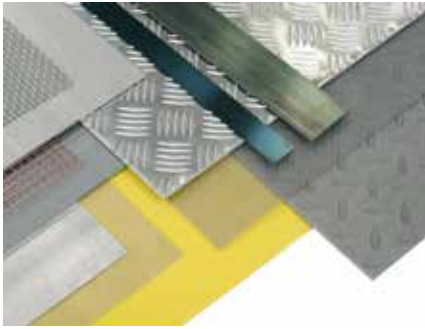

The sheet support system guides even thin materials exactly to the CNC backstop.

Front stops (available also with a precision scale) allow an accurate part positioning.



Small parts chute for sorting small blanks.



Spacious scrap container



Side free space for an easy blade change

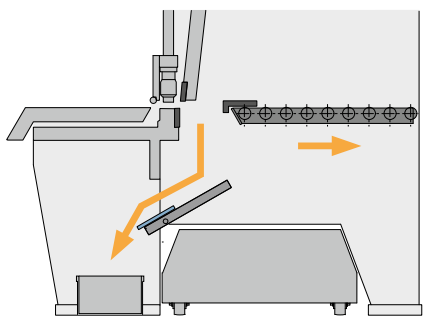

The programmable small parts chute delivers cut pieces (max. 200 x 500 mm) into a container in front of the machine.

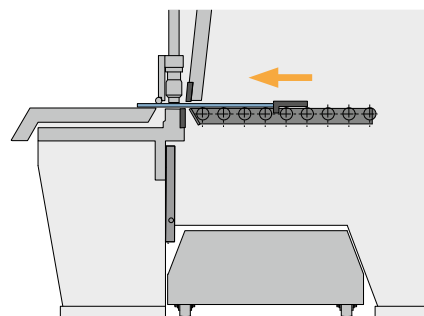

Return-back function: The CNC backstop can push a cut piece below the finger protection back to the operator. Less running around, more production time.

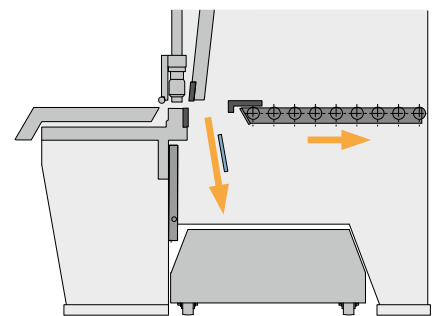

For trim cuts the sheet support moves backwards so that cut strips can fall into the spacious scrap container.

Technical data	Cutting length max.	Sheet thickness max.	Gauging depth
POWERcut RAS 86.43	4040 mm	5.0 mm	5 - 1000 (1500) mm
POWERcut RAS 86.33	3190 mm	6.3 mm	5 - 1000 (1500) mm

Swing Beam Shears

PRIMEcut

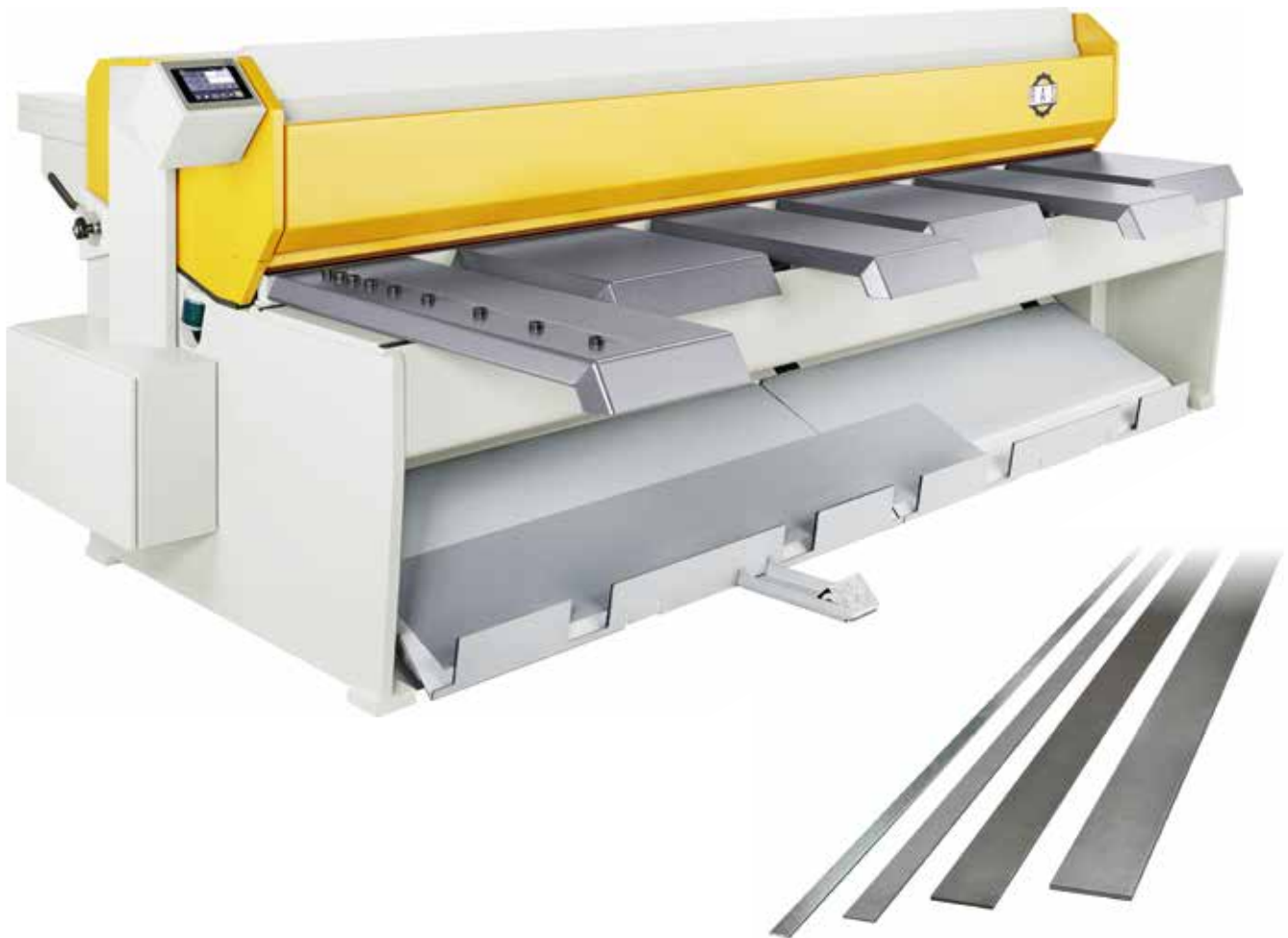

Twist free cutting even on small strips



Control with touch screen monitor



Lever for the cutting gap adjustment on the PRIMEcut.

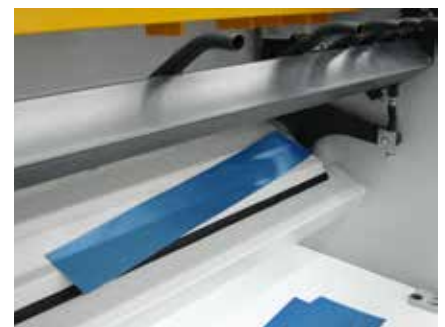

Parts chute for cut piece delivery to the rear.

SMARTcut

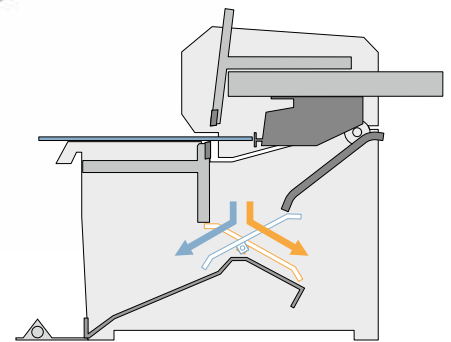

Sort cut pieces to the rear or the front.

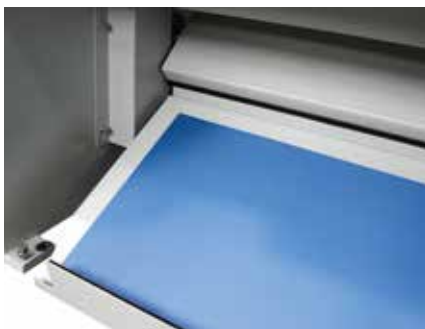

Parts chute for cut piece delivery to the front.



The foot lever switches the parts chute direction.



Convenient blank alignment with the LED cutting line illumination.

Technical data	Cutting length max.	Sheet thickness max.	Gauging depth
PRIMEcut RAS 53.30	3100 mm	3.0 mm	5 - 750 mm
SMARTcut RAS 52.30	3100 mm	2.0 mm	5 - 750 mm
SMARTcut RAS 52.25	2540 mm	2.0 mm	5 - 750 mm

Swaging Machines

EasyFormer



„Teach“ function



„Automatic“ function



Flanging wheels FL: Flanging without swiveling the part.



Crimping bead



Double seaming wheels



Swaging wheels for insulation work



Screw-in seam



Hose seam for hydraulic pipes



Glass panel touch control



Stop plate for insulation pipes



UnLock function opens the wheels immediately in an emergency.

Technical data	Sheet thickness max.	Wheel center distance	Working depth max.
EasyFormer RAS 12.65-2	3.0 mm	100 mm	400 mm
EasyFormer RAS 12.35-2	1.75 mm	63 mm	255 mm

Swaging Machines

RAS 11.35
RAS 11.15



9 pairs of wheels included



Swaging wheels



Technical data	Sheet thickness max.	Wheel center distance	Working depth max.
RAS 11.35	1.25 mm	50 mm	200 mm
RAS 11.15	1.25 mm	50 mm	200 mm

RAS 21.20



Top attachment for button punch



Automatic sheet guide system

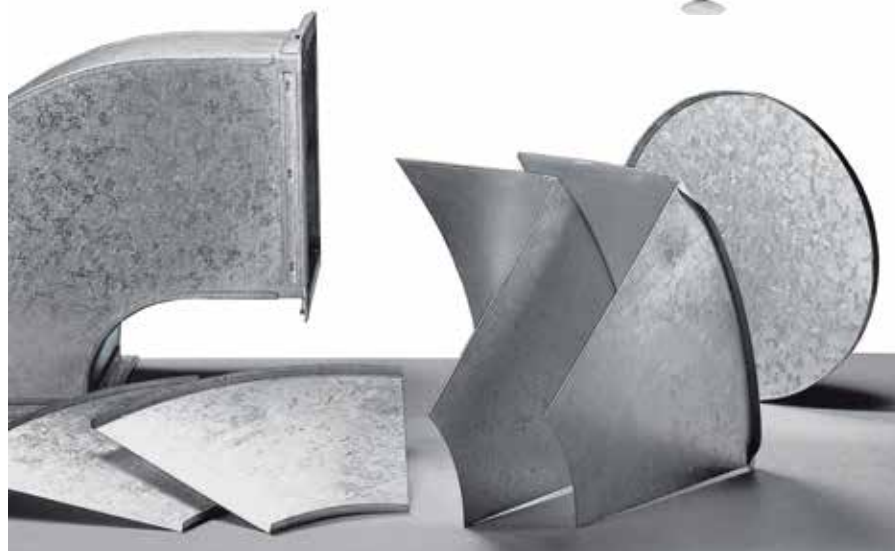

Production of edge flanges for air duct components.

Technical data	Sheet thickness max.	Fl. height (min. - max.)	Speed
RAS 21.20	1.5 mm	6 - 15 mm	0 - 9.4 m/min

Duct Seaming Machines

DuctZipper V-shape



Air duct with a single seam joint



Air duct with two seam joints



Air duct



DuctZipper with SealJet for maximum tightness and energy efficiency.

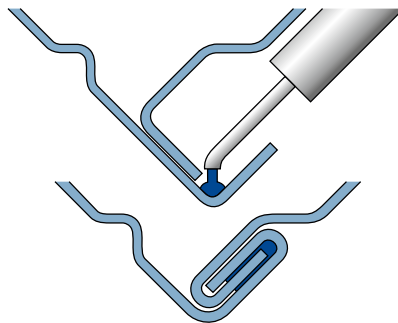

Duct seam inserted with gel sealant for the highest tightness requirements.



Autopilot and reinforced seaming bar on the RAS 20.12 DuctZipper.

DuctZipper L-shape



The DuctZipper in L-shape is specifically designed for large ducts. On the DuctZipper-L the working position is rotated by 45 degrees. The horizontal flange of the duct rests on the table while the vertical flange is directed straight up. Gripping grooves in the vertical wall let the operator easily hold and guide the duct while passing it through the machine.



Easily accessible forming rolls for maintenance work.



Improved seaming accuracy also results in a reduced distortion of the duct cross-section.



Operating speed doubled: After the first duct is finished and removed, the operator clamps the next duct with the AutoPilot and is ready to pass the next air duct through the machine.



Even very large ducts can be produced with only two operators.

Technical data	Sheet thickness max.	Duct cross-sec. min. Speed	Speed
DuctZipper RAS 20.12	1.0 - 1.25 mm	140 x 140 mm	15 m/min.
DuctZipper RAS 20.10	0.5 - 1.00 mm	100 x 100 mm	15 m/min.

Roll Forming Machines

SpeedySeamer

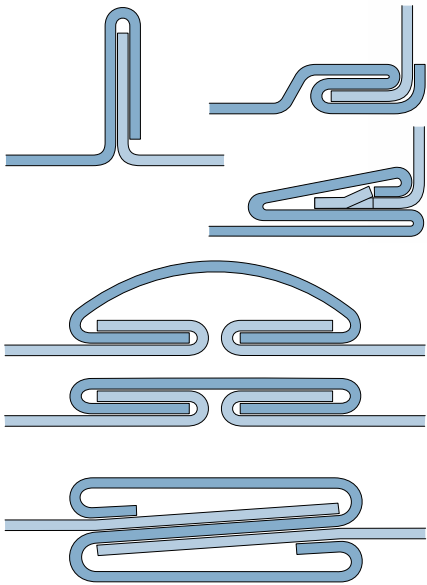

Standing seam, Pittsburgh seam, Snaplock seam, and „S“ seam



„S“ seam and drive cleat



Set of rolls for Pittsburgh seam



SpeedySeamer with lubricant spraying unit for stainless steel applications.

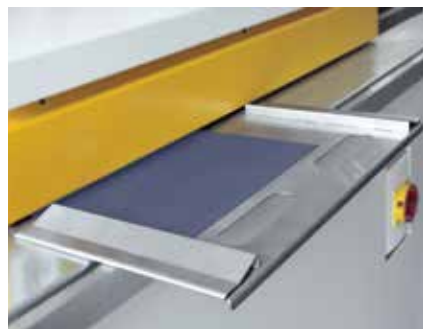

Small part material guide



Snaplock joint

Technical data	Sheet thickness max.	Rollforming stations	Speed
SpeedySeamer RAS 22.09	1.5 mm	9	16 m/min.
SpeedySeamer RAS 22.07	1.5 mm	7	16 m/min.

VENTrounder



For rounding elbow blanks with Snap-lock, Pittsburgh or Standing seams.



Scale for radius adjustments



Rolls easily adjustable to the width of the part



Stiffening pliers for consistent radii



Rolls for standing seams



Tape measure for quick roll positioning

Technical data	Sheet thickness max.	Working length	Speed
VENTrounder RAS 40.91	1.25 mm	1500 mm	10 m/min.

Seam Closing Machine

RAS 25.15

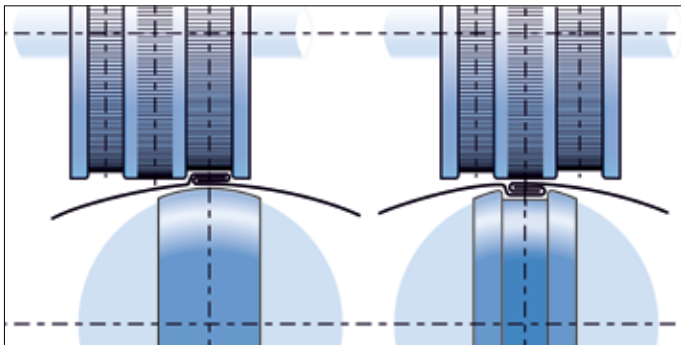

For closing inside and outside seams on round pipe.



Technical data	Sheet thickness max.	Working length	Shaft diameter
RAS 25.15	0.88 mm	1520 mm	90 mm

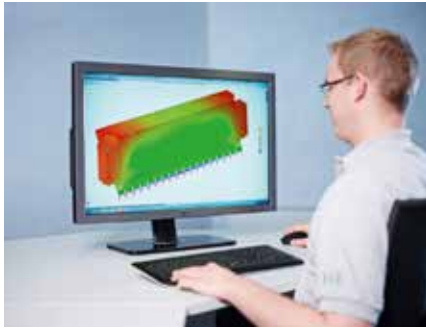

Design



Sawing



Plasma cutting



Milling



Turning



Grinding



Welding



Powder coating



Assembly



Electrical assembly



Quality inspection



RAS - Regional production for global sustainability



INNOVATION MADE IN GERMANY



06. 2017



Headquarters in Sindelfingen. In the foreground „Steel object“.



Efringen - factory and artwork



RAS Systems LLC in Georgia, USA

All sheet thickness refer to 400 N/mm² tensile strength. Subject to changes. Pictures may show options.



Founder Wilhelm Reinhardt



Managing Directors Rainer Stahl and Willy Stahl

RAS Reinhardt Maschinenbau GmbH

Richard-Wagner-Straße 4-10 | 71065 Sindelfingen

Fon: + 49-7031-863-0 | info@RAS-online.de

www.RAS-online.de